

Proposed 6-Storey Condominium Development,  
Herrema Boulevard and Low Boulevard  
Town of Uxbridge  
Evendale Developments Ltd.

---

# **SERVICING AND STORMWATER MANAGEMENT REPORT**

January 2021

MAEL Reference 20-028





# **SERVICING AND STORMWATER MANAGEMENT REPORT**

## **Proposed 6-Storey Condominium Development**

**For**

**Evendale Developments Ltd.**

**TOWN OF UXBRIDGE**

January 2021

Prepared by:



MASONGSONG ASSOCIATES ENGINEERING LIMITED  
7800 Kennedy Road, Unit 201  
Markham, Ontario • L3R 2C7  
T (905) 944-0162 • F (905) 944-0165

## Table of Contents

	<b>Page</b>
<b>1.0 Introduction</b>	<b>1</b>
<b>2.0 Background</b>	<b>1</b>
2.1 Previous Study	2
<b>3.0 Existing Drainage and Services</b>	<b>3</b>
<b>4.0 Storm Drainage and Stormwater Management</b>	<b>4</b>
4.1 Existing Storm Sewers and Drainage	4
4.2 Allowable Discharge	4
4.3 Post Development Discharge	4
<b>5.0 Erosion &amp; Sediment Control</b>	<b>8</b>
<b>6.0 Conclusions and Summary Recommendations</b>	<b>9</b>

## **1.0 INTRODUCTION**

Masongsong Associates Engineering Limited has been retained by Evendale Developments Ltd., to prepare this Servicing and Stormwater Management Report in support of a Site Plan Application for the development of a proposed 6-storey condominium development in the Town of Uxbridge.

The purpose of this report is to identify the requirements for site servicing and stormwater management as it relates to the Town of Uxbridge and the Region of Durham design criteria, and to demonstrate how the proposed site will function within the framework of existing infrastructure.

## **2.0 BACKGROUND**

The proposed development site comprises of a rectangular-shaped lot of approximately 0.50 ha (1.23 ac) located within the Evendale Developments Ltd. Brock Street Development, Subdivision (S-U-2017-03), located north-east of Brock Street East and Donland Lane. See Figure 1, for location key plan.

The site is bounded to the north by the future Low Boulevard, to the east by the future Herrema Boulevard, to the south by Brock Street East, and to the west by Donland Lane. Figure 1 below illustrates the location of the proposed development.

**Figure 1** Key Location Plan

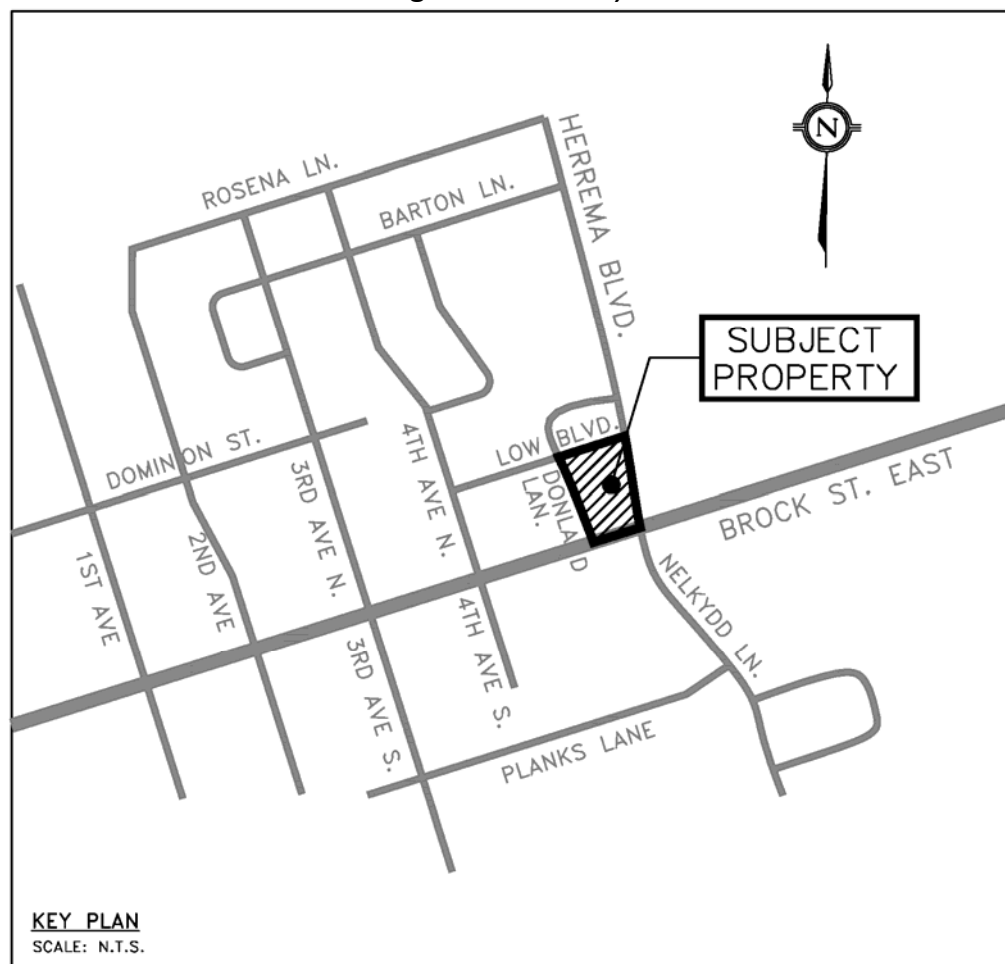

The proposed 6-storey condominium development will comprise of a total of 86 residential units with one level of underground parking. Vehicular entrance is located off Low Boulevard.

The proposed layout of the site is reflected in the Site Plan Included in the Drawings Appendix.

## 2.1 Previous Studies

The development block was supported by several studies, notably including the *Road Stormwater Conveyance Report – Brock Street and Herrema Boulevard* by Coles Engineering Group Ltd., dated Sept. 2019.

This current report for the subject block relies on the acceptance of the above report and drawings as the basis for receiving system capacity and stormwater control targets.

### 3.0 DRAINAGE AND SERVICE CONNECTIONS

The subject site is relatively flat with majority of the flow drains from south to north towards the proposed temporary DICB located at the northeast of the site.

The subject land is currently serviced by full municipal services within Low Boulevard and Herrema Boulevard, including watermain, sanitary and storm laterals. The existing service connections is excerpted from the subdivision design enclosed in Appendix A as Drawing No. GP-01, GR-01, PP-01, STM-01, STM-03, SAN-01 & SAN-02.

**Sanitary Service** The development block is presently serviced with an existing 200 mm lateral off Herrema Boulevard, terminated in an existing control maintenance hole at the north-east property line (Control MH-AG15-0099).

The previously approved design sheets for the subdivision allowed for an area of 0.39 ha. and a flow of 0.81 L/s from the subject block.

The more accurate site statistics of the current proposal was used to update the spreadsheet. With an area of 0.39 ha., and a unit count of 86 units, the resulting populations is **213 persons** (23 units-1 bedroom, 42 units-2 bedroom, & 21 units-3 bedroom), the resulting proposed peak sanitary sewage generation rate is **3.54 L/s.**

As confirmed in the subdivision sanitary design sheet (Drawing No. SAN-02), the existing downstream sanitary sewers on Herrema Boulevard from the subject site to EX. MH-AG15-0034 have enough capacity to accommodate the total sewage flow including the addition of the subject development.

**Watermain Service** The development block is presently serviced with an existing 150 mm and 100 mm diameter waterlines off Low Boulevard, both with existing valve & box at the north-east property line. However, due to the layout and design of the building with underground ramping at this location, the waterlines will need to remove, and a new 150 mm diameter water service lateral will need to be proposed off the existing 200 mm diameter PVC watermain on Herrema Boulevard.

The 150 mm waterline will serve as the fire line and the 100 mm

diameter waterline will serve as the domestic cold-water supply. Both fire and domestic waterlines will be extended to the P1 parking will be provided with water meters in accordance with Region standards.

As per Region of Durham's Water Supply System By-Law, watermains shall be sized to carry the greater of maximum day plus fire flow or maximum hour demand as outlined in the current edition of "Water Supply for Fire Protection, A Guide to Recommended Practice" issued by the Fire Underwriters Survey (FUS).

Based on the more stringent Fire Underwriters Survey (FUS) calculations in Tables F2-F3 (Appendix B), the required fire flow is 7,000 L/min.

A hydrant flow test, enclosed in Appendix B, was performed in October 2017 to ascertain the available municipal supply on Low Boulevard. Two hydrants are within close proximity to the site: one is at the west of the property (6 Low Blvd.), and another is at the southwest of Low & Donland Lane, 62m from the first hydrant.

Detailed hydrant flows are calculated in Table F1, confirming that the existing Low Boulevard system is capable of delivering a fire flow of **12,185 L/min.** which satisfies both FUS and the residential fire flows of 7,000 L/min.

### **Storm Service**

The development block is presently serviced with an existing 375 mm lateral off Herrema Boulevard, terminated in an existing control maintenance hole at the north-east property line (MH16). An existing DIC is temporary installed at the north-east of the to take drainage from the subject block into the downstream storm sewers on Herrema Boulevard.

As per the approved drainage plan (Drawing No. STM-01), a maximum allowable of 3.5 L/s can discharge from the subject site. The implementation of on-site stormwater management will be discussed in more detail in the following section.



## 4.0 STORM DRAINAGE AND STORMWATER MANAGEMENT

### 4.1 Allowable Discharge

The maximum allowable discharge from the subject block is 3.50 L/s as indicated on the approved Coles stormwater conveyance report and on the approved subdivision storm drainage plan (Drawing No. STM-1).

### 4.2 Post Development Discharge – Quantity Control

To meet the stormwater quantity control objectives, the subject site is proposed to provide on-site water quantity control up to the maximum allowable release rate of 3.5 L/s. Control devices in the form of roof controlled and inlet control will be implemented.

A post-development drainage plan is attached as Dwg. No. POST in Appendix C for reference.

- **Roof Control – A.1**

The proposed building has an approximately roof area of 0.1653 hectares. The rooftop will be designed to the most current Ontario Building Code (OBC) structural standards and will be capable of storing a quantity of stormwater on its surface. To gain the necessary storage volume, we propose to implement flow control drains that will allow a total release rate of 42 L/s/ha, a typical industry norm. Roof controls are typically specified at the working-drawing stage of building designs as they necessarily need to be coordinated between the architect, mechanical and structural engineers. Roof scuppers will need to be provided for emergency overflow or for events exceeding the 100 year storms. In practice, the roof ponding areas will need to be determined by roof and column geometry at the time of building design. As guidance for the working drawing stage, the following Table 1 provides the target roof release rates.

**Table 1** Rooftop Discharge Criteria

Area I.D.	Controlled Method	Rooftop Area (ha)	Post Release Rate (L/s) 100-year
A.1	42 L/s/ha	0.1653	6.94

We have determined the roof drain notch configuration required to generally comply with the above release rates. Our calculation is based on the following parameters:

- 4 - **Zurn105** units with a **465 notch area rating**, having **1 notch per drain**

The actual release rate from the four (4) roof control devices is calculated to be **7.44 l/s** as per Table C1 in Appendix C.

The utilization of controlled flow roof drains will require that stormwater storage be provided on the roof. An analysis of the stormwater storage required has been conducted and included in Appendix C, Table C2. Based on our calculation the corresponding ponding volume required on the roof will be **64.0 m<sup>3</sup>**.

The storage that can be provided on the proposed building rooftop is **68.6 m<sup>3</sup>** as per the following calculation:

$$\begin{aligned}\text{Roof storage capacity} &= (\text{roof area} \times \text{depth of ponding at roof drains}) / 3 \\ &= (1653 \text{ m}^2 \times 0.1245\text{m}) / 3 \\ &= 68.6\text{m}^3\end{aligned}$$

Therefore, the proposed building rooftop can accommodate the required volume needed for storage.

The project's mechanical engineer will need to accommodate the allowable roof release rate and storage volume will be met through their design. Ultimately the mechanical engineer should certify that the roof controls conform to our proposed stormwater management scheme.

- **Inlet Control – A.2**

Discharge from area A.2 is proposed to be controlled using an inlet control device. Due to the allowable low discharge rate of 3.5 L/s, traditional orifice control tube will yield a much larger flow rate or it will required a very small orifice tube with very short water head that is not practical for this site. Newer technologies like the *Hydrovex vertical vortex flow regulator* or the *IPEX inlet control device (tempest LMF ICD)* can provide a precise control of low flow using a larger opening than a conventional orifice tube making it less likely to clog.

An analysis of the storage required to attenuate the site discharge is provided in Appendix C, Table C3.

In summary, total volume required with the installation of a tempest LMF ICD will require onsite storage of **140 m<sup>3</sup>**.

Total storage provided in the proposed underground storage tank is approximately **150 m<sup>3</sup>**. Refer to Detail Plan (DET1) in the Appendix Drawings for detail design of the underground storage tank.

A summary of the storage required versus provided is shown below in Table

**Table 4.1** Stormwater Management Quantity Control Summary

Description	Total Area (ha.)	Avg. Runoff Coefficient "C"	Maximum Release Rate (L/s)	Required Storage (m <sup>3</sup> )	Provided Storage (m <sup>3</sup> )
Rooftop Controlled	0.1653	0.90	7.44 (4-Zurn 105)	64	68
Inlet Controlled	0.3347	0.70	3.75 (Tempest LMF ICD)	140	150
<b>Total</b>	<b>0.5000</b>	<b>0.76</b>	<b>3.75</b>	<b>204</b>	<b>218</b>

### 4.3 Major System Controls

The emergency overland flow route will not impact the building as the grading of the site ensures storm flows greater than 100 years will be able to flow overland off the site and have no impact to the proposed building and adjacent public and private properties. The overland flow will flow towards Low boulevard via the proposed driveway entrance as originally intended within the subdivision designed. Maximum ponding depth is 0.15m.

### 4.4 Quality Control

#### TSS REMOVAL

To satisfied the quality control requirement as set by the LSRCA and the Region, the subject site will be provided by the proposed Oil-grit separator (OGS) with ETV certified as indicated in the approved *Road Stormwater Conveyance Report – Brock Street and Herrema Boulevard by Coles Engineering Group Ltd., dated Sept. 2019*. As excerpted from the Coles Report:

*“As discussed with the LSRCA and the Region, an OGS unit that is ETV certified has been agreed to be used to satisfy quality control as a result of the loss of the ditches.”*

A Stormceptor Model EF04 unit is required and to be installed. This unit has been sized to treat the impervious areas based on a minimum 80% TSS removal.

The following table summarizes the data used for sizing the OGS and the associated treatment values.

Table 2: *Oil-Grit Separator Sizing and Treatment Information*

<b>Outlet Location</b>	<b>Contributing Area (ha)</b>	<b>Runoff Coefficient (C)</b>	<b>Oil-Grit Separator Model</b>	<b>TSS Removal (%)</b>
Herrema Boulevard	0.500	0.76	EF04	83

**Note:** Detailed calculations can be found in Appendix C.

## **WATER BALANCE**

WSP completed a Water Balance Study for site (excerpts are attached in Appendix D).

Based on the finding, the pre-development water budget reflects infiltration for the site of approximately 2,216 m<sup>3</sup>/yr. The post-development water budget predicts a total on-site infiltration of 818 m<sup>3</sup>/yr. Overall, this is a decrease of 63% relative to the pre-development case, and represents an infiltration deficit of 1,399 m<sup>3</sup>/yr.

To meet the water balance deficit, additional LID measures will need to be implemented on-site. However, due to the low permeability of the natives and high water table and conditions associated to the design of the building with an underground parking area and servicing easement there is no practical opportunity for additional LID measures to implement on-site. Therefore, the water balance deficit will be in the form of cash in-lieu to support initiatives to off-set infiltration within the LSRCA.

## 5.0 GROUNDWATER CONSIDERATION

WSP completed a Hydrogeological Assessment regarding the groundwater needs for the site (excerpts are attached in Appendix D).

### **Short Term Discharge (During-Construction):**

Temporary ground water control will be required during construction activities to provide safe dry working conditions. As indicated on page 17 of the hydrogeological report, the maximum short-term discharge rate of **176,600 L/day (or 2.04 L/s)** will be required to be removed over a 1-day during construction. Under the MECP requirements, a registered on the Environmental Activity Sector Registry (EASR) system is required when dewatering is greater than 50,000 L/day and less than 400,000 L/day. A Permit-to-Take-Water (PTTW) is required when dewatering is expected to be greater than 400,000 L/day. As the construction dewatering is above the 50,000 L/day but below the 400,000 L/day threshold; only an EASR is required.

The selection and design of the dewatering system should be prepared by a qualified dewatering contractor. At the time of construction and prior to the dewatering activities, the dewatering contractor will need to ensure that quantity and quality of the groundwater flow must comply with the Region Sewer Use By-Law.

### **Long Term Discharge (Post-Construction):**

Based on the hydrogeological finding, the water level data suggests that the majority of the foundation will be below the seasonally high water table with an estimated long-term dewatering rate up to **85,500 L/day (0.99 L/s)**. Based on the recommendation of WSP and input from the owner, the building foundation/underground parking is proposed to be waterproof (bath-tub design); and thereby complying with Policy DEMD-1. Therefore, there is no proposed long-term groundwater discharge from the subject site.

## 6.0 EROSION AND SEDIMENT CONTROL

Erosion and sediment control should be implemented for all construction activities within the subject site, and for each consecutive phase and stage of construction, including earthworks, servicing and building activities. The basic principles considered for minimizing erosion, sedimentation, and resultant negative environmental impacts include:

- Minimize local disturbance activities (e.g. grading);
- Expose the smallest possible land area to erosion for the shortest possible time;
- Implement erosion and sediment control measures before the outset of construction activities; and,
- Carry out regular inspections of erosion and sediment control measures and repair or maintain as necessary.
- Erection of silt fences around all site perimeters;
- Provide sediment traps (e.g. rock check dams, straw bales, scour basins) along interceptor swales and points of swale discharge;
- Inlet controls at catchbasins, comprising filter cloth overlain with rip-rap;
- Implement a weekly street sweeping and cleaning program for any mudtracking onto the adjacent municipal roadways;
- Provide gravel “mud mats” at construction vehicle access points to minimize off-site tracking of sediments; and,
- Confine refueling/servicing equipment to areas well away from inlets to the minor system or major system elements.
- All waste and unused building materials (including garbage, cleaning wastes, wastewater, toxic materials, or hazardous materials) shall be properly disposed of and not allowed to be mixed with and carried off by runoff from the site into a receiving watercourse or storm sewer.

Removal of the erosion and sediment controls should be done once construction is completed and sediment run-off from the construction activities has stabilized. An Erosion and Sediment Control Plan (ESC1) is attached in Appendix Drawings.

## 7.0 CONCLUSIONS AND SUMMARY RECOMMENDATIONS

This Site Servicing and Stormwater Management Report has demonstrated that the proposed development can be accommodated by the existing local infrastructure. Specifically:

- **Sanitary Service** will be accommodated by the existing 200 mm diameter PVC sanitary connection located on Herrema Boulevard. A 200 mm diameter PVC sanitary sewer line is proposed to extend into the building. A unit count and analysis of the downstream system on Herrema Boulevard confirms there is adequate residual capacity to accommodate the subject site.
- **Water Service** will be accommodated by the existing 200 mm municipal watermain located on Herrema Boulevard. A 150 mm service line will be tapped off the main to provide fire service with a 100 mm domestic branch at the streetline. Both fire and domestic waterlines will be extended to the P1 parking where it will be provided with water meters in accordance with Region standards. Hydrant flow tests and analysis confirms there is adequate supply and pressure for firefighting purposes.
- **Storm Drainage** will be collected onsite and discharged into the existing 375 mm diameter lateral with a maximum discharge of 3.50 L/s as per the subdivision design. The required volumes will be achieved in the proposed underground storage tank and within the rooftop area.
- **Water Balance** deficit will be in the form of cash in-lieu to support initiatives to offset infiltration within the LSRCA due to soil conditions and design of the building.
- **TSS Removal** will be achieved by installing an OGS Stormceptor model EF04 sized to provide quality control to 83% TSS removal.
- **Groundwater** during construction is estimated with a maximum discharge rate of 85,500 L/day (0.99 L/s). The selection and design of the dewatering system should be prepared by a qualified dewatering contractor. At the time of construction and prior to the discharge of groundwater into the municipal sewer system, the dewatering contractor will need to ensure that quantity and quality of the groundwater flow must comply with the Region Sewer Use By-Law.

**Long-Term groundwater** discharge is not required for the site as the building foundations/basement are proposed to be waterproof.

- **Erosion and sediment controls** will need to be implemented during development until the site has been stabilized with groundcover.

We trust you will find this submission is complete and in order. Should you have any questions or require additional information, please contact the undersigned.  
Respectfully Submitted,

**MASONGSONG ASSOCIATES ENGINEERING LIMITED**



Professional Engineers  
Ontario

**Limited Licensee**

Name: K. K. LO  
Number: 100209166

Category: CIVIL

**Limitations:**

This licence is subject to the limitations as detailed on the certificate.

Association of Professional Engineers of Ontario

Ken Lo, LEL  
Project Manager

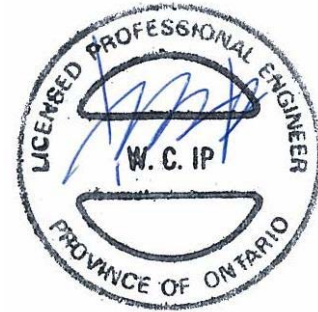

Andrew Ip, P. Eng.  
Principal



## **APPENDIX A**

### **- Subdivision Plans**



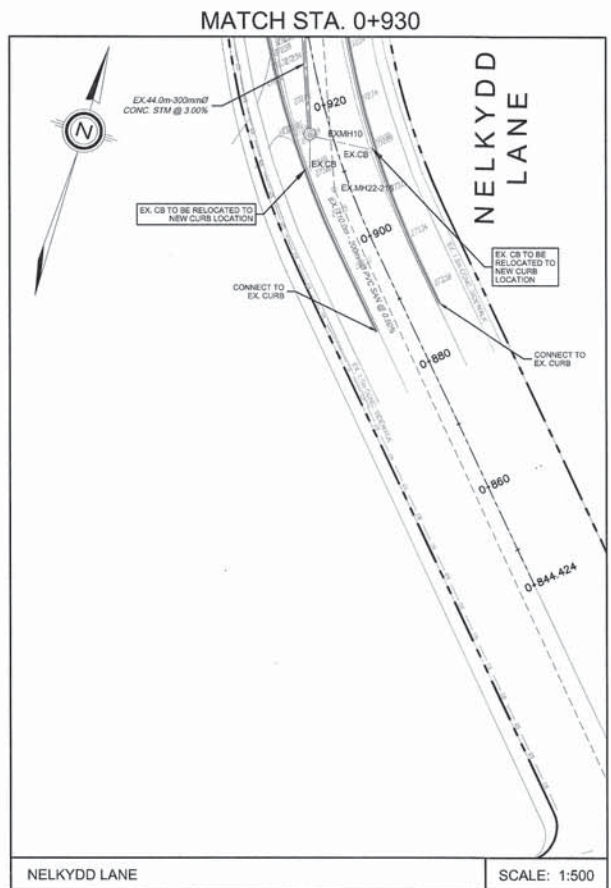

SCALE: 1:500

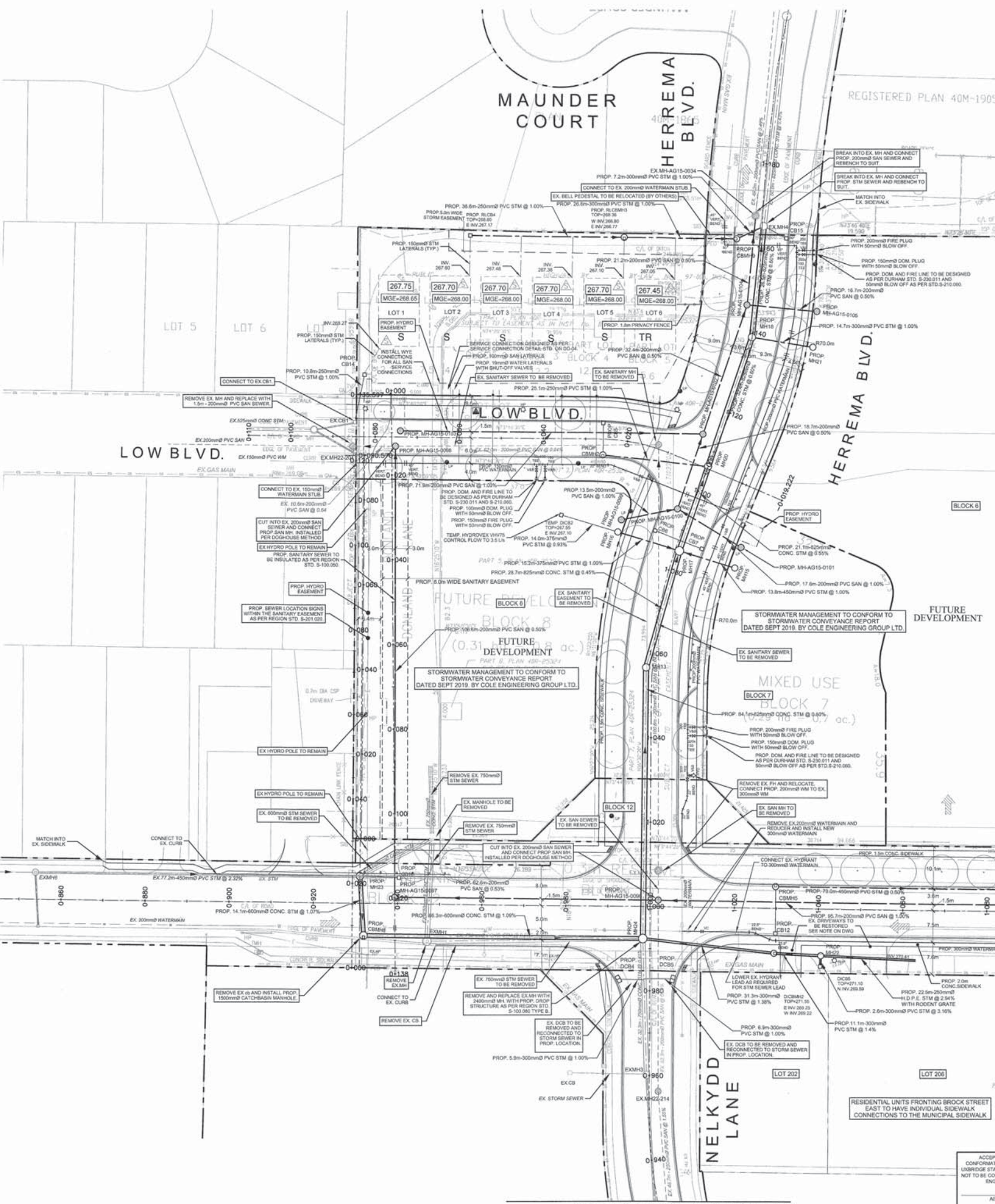

**LEGEND**

- PROPERTY LINE
- PROPOSED STORM PIPE
- PROPOSED SANITARY PIPE
- PROPOSED WATERMAIN
- PROPOSED SANITARY MANHOLE
- PROPOSED STORM MANHOLE
- PROPOSED CATCH BASIN MANHOLE
- PROPOSED CATCH BASIN
- PROPOSED DOUBLE CATCH BASIN
- EXISTING MANHOLE
- EXISTING DOUBLE CATCH BASIN
- EXISTING CATCH BASIN
- PROPOSED VALVE AND BOX
- PROPOSED FIRE HYDRANT
- TEMPORARY FLUSHING HYDRANT
- LOT NUMBER
- RELOCATED HYDRO POLE (BY OTHERS)
- PROPOSED HYDRO POLE (BY OTHERS)
- PROPOSED STREET LIGHT POLE (BY OTHERS)
- PROPOSED TRANSFORMER (BY OTHERS)
- EXISTING OVERLAND FLOW ROUTE
- PROPOSED SEWER EASEMENT
- PROPOSED HYDRO EASEMENT
- PROPOSED SUMP PUMP - DISCHARGE TO GRADE ON TO SPLASH PADS
- EXISTING GASMAIN
- MINIMUM GOOSE NECK ELEVATION
- SUGGESTED BASEMENT FLOOR ELEVATION

**SURVEYOR INFORMATION**

J.D. BARNES LIMITED  
110 SCOTIA COURT, #40  
WILSON, ON L9W 5Y7  
PHONE: (905) 723-1212  
FAX: (905) 723-4234

H.F. GRANDER Co. LIMITED  
ONTARIO LAND SURVEYOR  
1075 HIGHWAY 7A WEST, UNIT 3A  
PORT FERRY, ON L4L 1A6  
PHONE: (905) 966-9600  
FAX: (905) 966-2447

**BENCHMARK INFORMATION:**  
MINISTRY OF TRANSPORTATION OF ONTARIO PRECISE BENCHMARK N° 00819779487 (AKA 779487), TWO STOREY RED BRICK HOUSE ON SOUTH SIDE OF HIGHWAY 47 (BROCK STREET) IN THE TOWN OF UXBRIDGE, 118.8m EAST OF MARSETTA STREET, 18.4m WEST OF FRANKLIN STREET AND 15.9m SOUTH OF THE CENTRELINE OF HIGHWAY 47. TABLE IS SET HORIZONTALLY IN THE EAST FACE OF CONCRETE FOUNDATION, 3.8m SOUTH OF NORTHEAST CORNER, 30m ABOVE GROUND LEVEL AND 34cm BELOW BRICKWORK. ELEVATION = 274.359m (GEOIDETIC)

NO.	REVISION	DATE	BY
8	ISSUED FOR CONSTRUCTION	JAN 16, 2020	PS
7	FOR APPROVAL	DEC 06, 2019	PS
6	REGION AND TOWNSHIP SUBMISSION	OCT 28, 2019	PS
5	LSRCA SUBMISSION	SEPT 13, 2019	PS
4	100% SUBMISSION	JUNE 28, 2019	PS
3	ISSUED FOR LSRCA APPROVAL	JUNE 20, 2019	PS
2	90% SUBMISSION	MAR 25, 2019	PS



**THE REGIONAL MUNICIPALITY OF DURHAM**

**TOWN OF UXBRIDGE**

**COLE ENGINEERING GROUP LTD.**  
70 Valleywood Drive,  
Markham, ON L3R 4T5  
T: 416 887 6161 | F: 905 940 6161  
www.coleengineering.ca

**EVENDALE DEVELOPMENTS LTD.**  
BROCK STREET DEVELOPMENT  
UXBRIDGE, ONTARIO

**GENERAL PLAN - WEST**

DESIGNED BY: PS	DATE: JANUARY 2019	CHECKED BY: NG
DRAWN BY: PS	PROJECT No: 2017-0569	DRAWING No: GP-01
SCALE: 1:500		

**SANITARY LATERALS AT PROPERTY LINE**

UNITS	INVERTS
1	266.89
2	266.72
3	266.80
4	266.48
5	266.37
6	266.23

- DRIVEWAY RESTORATION:**
- DRIVEWAY ACCESS TO BE MAINTAINED AT ALL TIMES.
  - RESIDENTS TO BE GIVEN MIN. 24 HRS NOTICE PRIOR TO CONSTRUCTION - RESTORATION WORKS.
  - DRIVEWAYS TO BE RESTORED WITH 40mm H.B. 150mm GRANULAR 'K'.

ACCEPTED TO BE IN GENERAL CONFORMANCE WITH THE TOWNSHIP OF UXBRIDGE STANDARDS THIS ACCEPTANCE IS NOT TO BE CONSIDERED AS VERIFICATION OF ENGINEERING CONTENT

AICOM CANADA LTD.  
DATE:

**APPROVED**

DEPARTMENT OF WORKS  
REGION OF DURHAM  
DATE:

SEE DETAIL ON THIS DRAWING

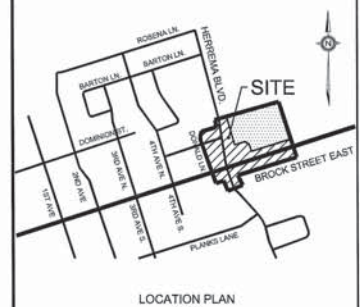
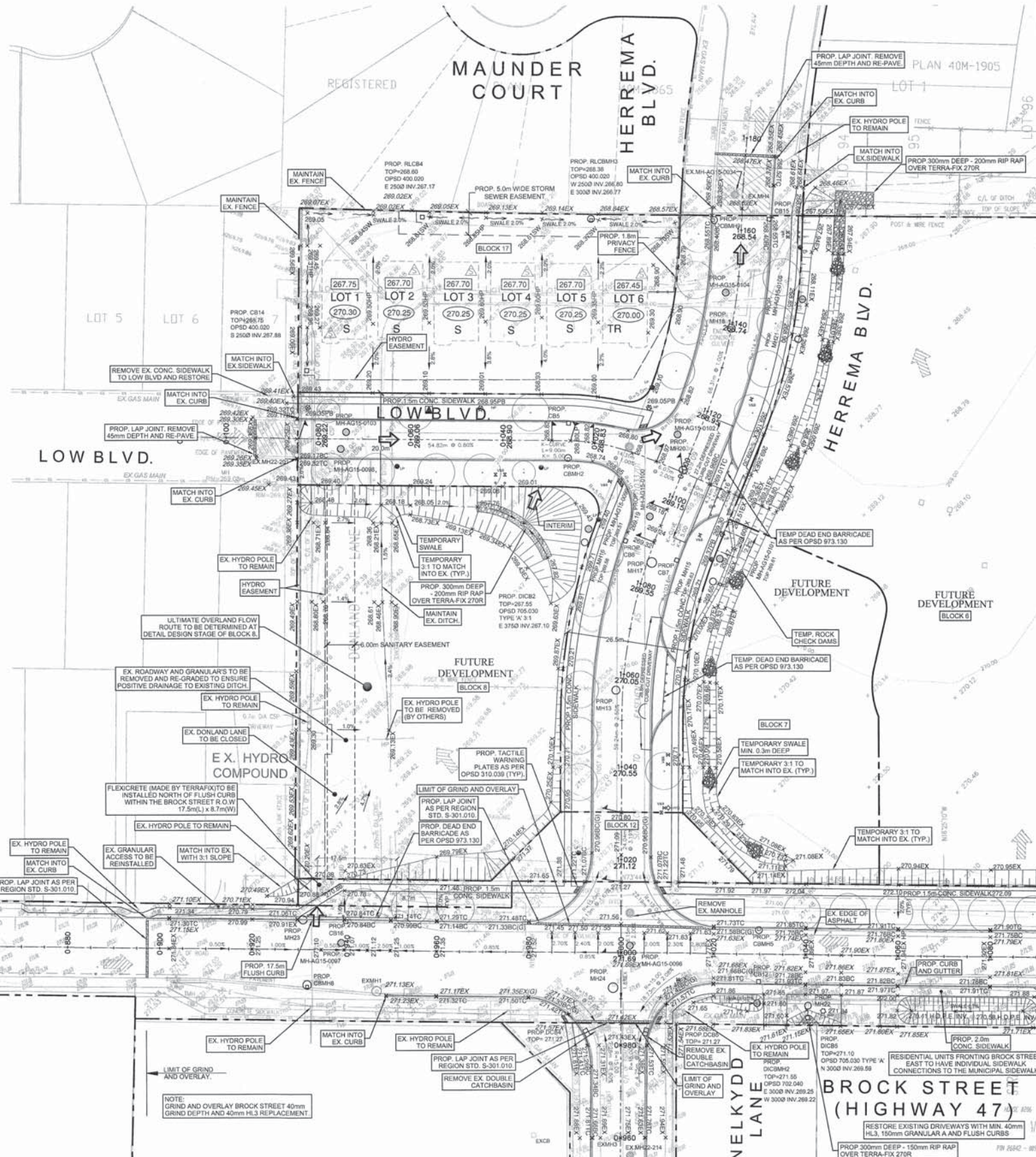
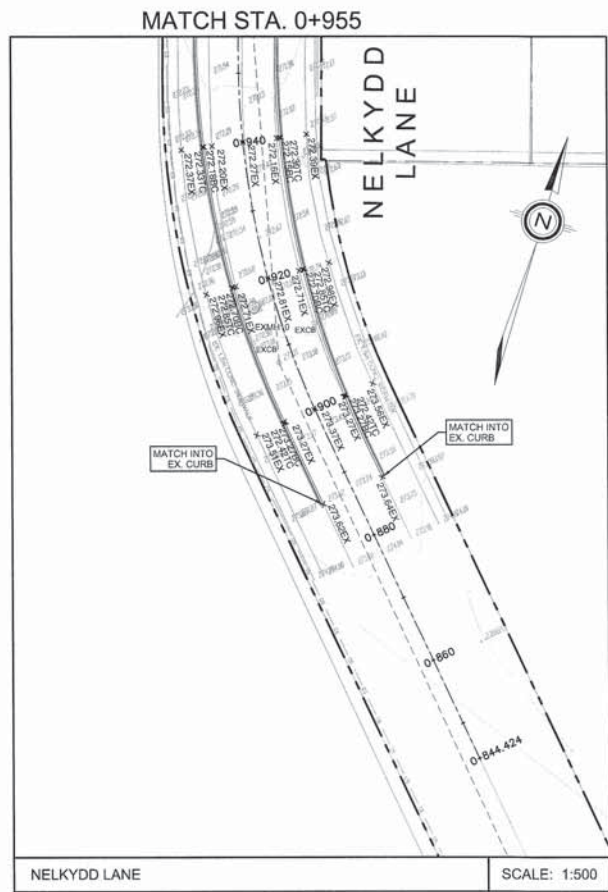

**LEGEND**

PROPERTY LINE	x 149.50
PROPOSED GRADE	x 149.53EX
EXISTING GRADE	x 149.65TC
PROPOSED GRADE (TOP OF CURB)	x 149.500C
PROPOSED GRADE (BOTTOM OF SWALE)	x 147.585W
PROPOSED GRADE (TOP OF WALL)	x 147.587W
PROPOSED GRADE (HYDRO POLE BASE)	x 147.58PB
PROPOSED SWALE	→
PROPOSED SLOPE (3:1 MAX.)	↘
PROPOSED SANITARY MANHOLE	○
PROPOSED STORM MANHOLE	○
PROPOSED CATCH BASIN MANHOLE	○
PROPOSED CATCH BASIN	□
PROPOSED DOUBLE CATCH BASIN	□
EXISTING MANHOLE	○
EXISTING CATCH BASIN	□
EMERGENCY OVERLAND FLOW ROUTE	→
EXISTING OVERLAND FLOW ROUTE	→
SUGGESTED BASEMENT FLOOR ELEVATION	123.12
SUGGESTED FINISH FLOOR ELEVATION	123.12
LOT NUMBER	1
PROPOSED SLUMP PUMP	○
RELOCATED HYDRO POLE	○
PROPOSED HYDRO POLE	○
PROPOSED LIGHT POLE	○
PROPOSED VALVE AND BOX	○
PROPOSED HYDRANT	○
SPLIT DRAINAGE LOT	○
TRANSITION LOT	○
PROPOSED FLUSH CURB	—
PROPOSED DEPRESSED CURB	—
PROPOSED SEWER EASEMENT	—
PROPOSED HYDRO EASEMENT	—
PROPOSED FLEXICRETE	—

**SURVEYOR INFORMATION**

J2 BARNES LIMITED  
110 SCOTIA COURT, #40  
WILLOWDALE, ON L3Y 1K7  
PHONE: (905) 723-2121  
FAX: (905) 723-4234

H.F. GRANDER Co. LIMITED  
ONTARIO LAND SURVEYOR  
1875 HIGHWAY 7A WEST, UNIT 24  
PORT PERRY, ON L8B 1A8  
PHONE: (905) 885-2600  
FAX: (905) 885-2347

**BENCHMARK INFORMATION:**  
MINISTRY OF TRANSPORTATION OF ONTARIO PRECISE BENCHMARK N° 0081979487 (AKA 778487). TWO STOREY RED BRICK HOUSE ON SOUTH SIDE OF HIGHWAY 47 (BROCK STREET) IN THE TOWN OF UXBRIDGE, 118.9m EAST OF MARETTA STREET, 15.4m WEST OF FRANKLIN STREET AND 15.9m SOUTH OF THE CENTRELINE OF HIGHWAY 47. TABLET IS SET HORIZONTALLY IN THE EAST FACE OF CONCRETE FOUNDATION, 3.9m SOUTH OF NORTHEAST CORNER, 30cm ABOVE GROUND LEVEL AND 34cm BELOW BRICKWORK. ELEVATION = 274.359m (GEOIDETIC)

NO.	REVISION	DATE	BY
8	ISSUED FOR CONSTRUCTION	JAN 16, 2020	PS
7	FOR APPROVAL	DEC 06, 2019	PS
6	REGION AND TOWNSHIP SUBMISSION	OCT 28, 2019	PS
5	LSRCA SUBMISSION	SEPT 13, 2019	PS
4	100% SUBMISSION	JUNE 28, 2019	PS
3	ISSUED FOR LSRCA APPROVAL	JUNE 20, 2019	PS
2	90% SUBMISSION	MAR 25, 2019	PS



**THE REGIONAL MUNICIPALITY OF DURHAM**

**TOWN OF UXBRIDGE**

**COLE ENGINEERING GROUP LTD.**  
70 Valleyview Drive,  
Markham, ON L3R 4T5  
T: 416 567 8151 | F: 905 940 6151  
www.coleengineering.ca

**GRADING PLAN - WEST**

DESIGNED BY: PS	DATE: JANUARY 2019	CHECKED BY: NG
DRAWN BY: PS	PROJECT No. 2017-0569	DRAWING No. GR-01
SCALE: 1:500		

ACCEPTED TO BE IN GENERAL CONFORMANCE WITH THE TOWNSHIP OF UXBRIDGE STANDARDS THIS ACCEPTANCE IS NOT TO BE CONSIDERED AS VERIFICATION OF ENGINEERING CONTENT

DATE: \_\_\_\_\_

**APPROVED**

ACCOM CANADA LTD. DEPARTMENT OF WORKS REGION OF DURHAM

DATE: \_\_\_\_\_

MATCH STA. 0+955  
REFER TO DETAIL ON THIS SHEET

REFER TO GR-02

MARK	DESCRIPTION	CHAINAGE	TOP OF WATERMAIN ELEVATION (m)
A	200mm $\phi$ PROP. WATERMAIN CONNECTED TO THE EXISTING 200mm $\phi$ WATERMAIN PLUG	1+015.22	269.02
B	200mm $\phi$ 22.5 $^{\circ}$ BEND	1+022.89	268.86
C	200mm $\phi$ 22.5 $^{\circ}$ BEND	1+025.74	268.79
D	200mm $\phi$ VALVE AND BOX	1+030.22	268.70
E	200mm $\phi$ TEE CONNECTION, VALVE AND BOX AND FIRE HYDRANT	1+031.19	268.68
F	200mm $\phi$ x 150mm $\phi$ TEE CONNECTION AND VALVE	1+040.61	268.48
G	200mm $\phi$ TEE CONNECTION AND VALVE	1+042.61	268.44
H	START OF 70m RADIUS DEFLECTION	1+056.39	268.36
I	200mm $\phi$ 45 $^{\circ}$ VERTICAL BENDS x4	1+082.56	266.36
J	END OF 70m RADIUS DEFLECTION	1+083.89	268.36
K	200mm $\phi$ VALVE AND BOX	1+094.61	267.05
L	200mm $\phi$ x 150mm $\phi$ TEE CONNECTION	1+098.28	267.00
M	200mm $\phi$ VALVE AND BOX	1+125.50	266.70
N	START OF 70m RADIUS DEFLECTION	1+129.95	266.61
O	END OF 70m RADIUS DEFLECTION	1+153.47	266.11
P	200mm $\phi$ x 150mm $\phi$ TEE CONNECTION AND VALVE	1+158.57	266.00
Q	200mm $\phi$ TEE CONNECTION AND VALVE	1+159.57	265.98
R	200mm $\phi$ 90 $^{\circ}$ BEND	1+160.07	265.96
S	200mm $\phi$ 45 $^{\circ}$ VERTICAL BEND x4	1+160.70	264.91
T	200mm $\phi$ 90 $^{\circ}$ BEND	1+160.70	264.91
U	CONNECT TO EXISTING 200mm $\phi$ WATERMAIN STUB WITH PROPOSED 200mm $\phi$ WATERMAIN	1+166.54	265.91

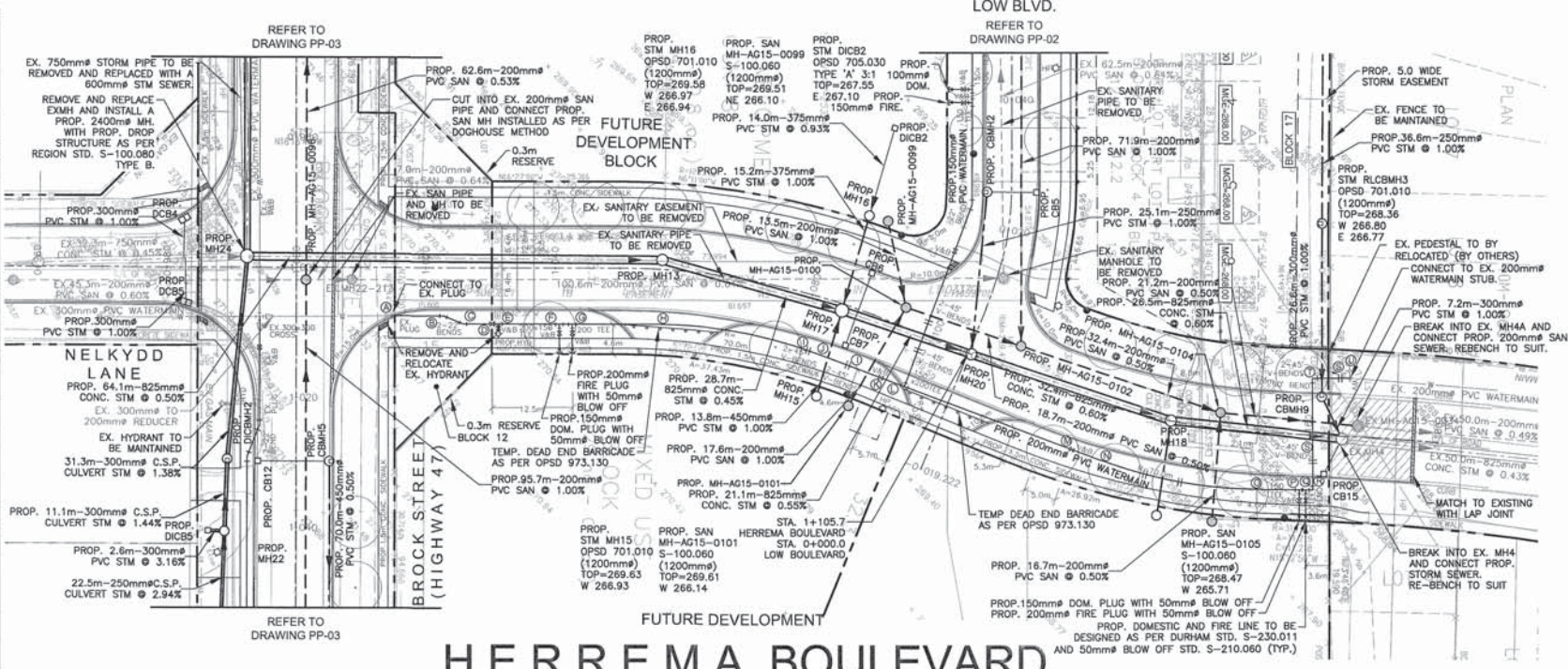

CATCH BASIN DATA				C.B. CONNECTION DATA				
OPSD	INV. No.	CHAINAGE	GRATE EP. ELEV.	INVERT ELEV.	LEN. (m)	DIA. (mm)	CLASS OF PIPE	GRADE (%)
705.020	400.020	4	0+982.50	271.30	-	269.80	5.9	300 SDR-35
705.020	400.020	5	0+982.77	271.29	-	269.79	6.9	300 SDR-35
705.010	400.020	6	1+087.41	269.25	-	267.80	7.0	250 SDR-35
705.010	400.020	7	1+087.63	269.24	-	267.79	4.9	250 SDR-35
705.010	400.020	15	1+162.60	268.40	-	266.95	5.3	250 SDR-35



**LEGEND**

- PROPERTY BOUNDARY
- PROPOSED SANITARY PIPE
- PROPOSED STORM PIPE
- PROPOSED SANITARY SERVICE CONNECTION
- PROPOSED WATER SERVICE CONNECTION
- PROPOSED STORM MANHOLE
- PROPOSED SANITARY MANHOLE
- PROPOSED SANITARY MANHOLE
- PROPOSED CATCH BASIN
- PROPOSED DOUBLE CATCH BASIN
- ⊗ PROPOSED VALVE & CHAMBER
- ⊗ PROPOSED VALVE & BOX
- ⊗ PROPOSED HYDRANT & VALVE
- ⊗ MINIMUM GOOSE NECK ELEVATION
- ⊗ PROP. PUMP STATION
- ⊗ LOT NUMBER
- ⊗ EXISTING STORM MANHOLE
- ⊗ EXISTING SANITARY MANHOLE
- ⊗ EXISTING CATCHBASIN
- ⊗ EXISTING VALVE & CHAMBER
- ⊗ EXISTING HYDRANT & VALVE
- ⊗ PROPOSED LIGHT POLE
- ⊗ PROPOSED LIGHT POLE
- PROPOSED EASEMENT
- PROPOSED EASEMENT
- 100 YEAR HGL

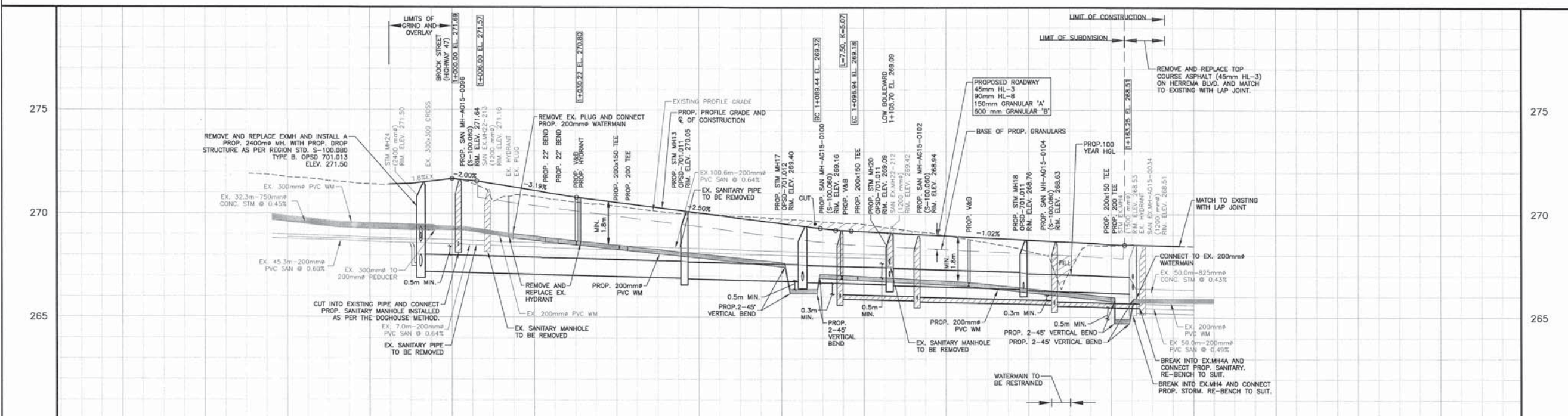

WATERMAIN LENGTH AND SIZES	SAN LENGTHS SIZES AND GRADES	SAN SEWER	STM LENGTHS SIZES AND GRADES	STM SEWER	EXISTING & PROPOSED C/L ELEV	C/L CHAINAGE
PROP. 129.3 OF 150mm, CLASS-150 (DR-18) PVC WATERMAIN, BEDDING AS PER CLASS P (S-200.010)	PROP. 18.7m - 200mm $\phi$ PVC SAN @ 0.50% (SDR-35) BEDDING AS PER CLASS P (S-200.010)	268.63 268.43 268.46 268.47	PROP. 64.1m - 825mm $\phi$ CONC. STM @ 0.50% (CL65-D) BEDDING AS PER OPSD 802.030, CLASS 'B'	271.69 271.69	271.69 271.69	0+920
	PROP. 28.7m - 825mm $\phi$ CONC. STM @ 0.45% (CL65-D) BEDDING AS PER OPSD 802.030, CLASS 'B'	269.56 269.56	PROP. 21.1m - 825mm $\phi$ CONC. STM @ 0.55% (CL65-D) BEDDING AS PER OPSD 802.030, CLASS 'B'	269.77 269.77	269.77 269.77	0+940
	PROP. 32.4m - 200mm $\phi$ PVC SAN @ 0.50% (SDR-35) BEDDING AS PER CLASS P (S-200.010)	269.81 269.81	PROP. 32.4m - 825mm $\phi$ CONC. STM @ 0.50% (CL65-D) BEDDING AS PER OPSD 802.030, CLASS 'B'	269.51 269.51	269.51 269.51	0+960
	PROP. 21.2m - 200mm $\phi$ PVC SAN @ 0.50% (SDR-35) BEDDING AS PER CLASS P (S-200.010)	269.63 269.63	PROP. 26.5m - 825mm $\phi$ CONC. STM @ 0.60% (CL65-D) BEDDING AS PER OPSD 802.030, CLASS 'B'	268.54 268.54	268.54 268.54	0+980
		268.45 268.45				1+000
						1+020
						1+040
						1+060
						1+080
						1+100
						1+120
						1+140
						1+160
						1+180
						1+200
						1+220
						1+240

**APPROVED**

ACCEPTED TO BE IN GENERAL CONFORMANCE WITH THE TOWNSHIP OF URBIDERE STANDARDS THE ACCEPTANCE IS NOT TO BE CONSTRUED AS VERIFICATION OF ENGINEERING CONTENT

ASICO CANADA LTD. DEPARTMENT OF WORKS REGION OF DURHAM

DATE: \_\_\_\_\_ DATE: \_\_\_\_\_

**SURVEYOR INFORMATION**

J.D. BARNES LIMITED 110 SCOTIA COURT, #46 WHITBY, ON L1N 8Y7 PHONE: (905) 723-1212 FAX: (905) 723-4234

H.F. GRANDER CO. LIMITED 5075 HIGHWAY 7A WEST, UNIT 2A PORT HURON, ON L4K 1W6 PHONE: (519) 985-3000 FAX: (519) 985-2387

**BENCHMARK INFORMATION:** MINISTRY OF TRANSPORTATION OF ONTARIO PRECISE BENCHMARK N° 00818778487 (AKA 778487), TWO STOREY RED BRICK HOUSE ON SOUTH SIDE OF HIGHWAY 47 (BROCK STREET) IN THE TOWN OF URBIDERE, 118.8m EAST OF MARSHETTA STREET, 18.4m WEST OF FRANKLIN STREET AND 15.8m SOUTH OF THE CENTRELINE OF HIGHWAY 47. TABLET IS SET HORIZONTALLY IN THE EAST FACE OF CONCRETE FOUNDATION, 3.9m SOUTH OF NORTHEAST CORNER, 30cm ABOVE GROUND LEVEL AND 34cm BELOW BRICKWORK. ELEVATION = 274.358m (GEOIDETIC)

NO.	REVISION	DATE	BY
8	ISSUED FOR CONSTRUCTION	JAN 16, 2020	PS
7	FOR APPROVAL	DEC 06, 2019	PS
6	REGION AND TOWNSHIP SUBMISSION	OCT 28, 2019	PS
5	LSRCA SUBMISSION	SEPT 13, 2019	PS
4	100% SUBMISSION	JUNE 28, 2019	PS
3	ISSUED FOR LSRCA APPROVAL	JUNE 20, 2019	PS
2	90% SUBMISSION	MAR 25, 2019	PS

**THE REGIONAL MUNICIPALITY OF DURHAM**

**COLE ENGINEERING GROUP LTD.**  
70 Valleywood Drive, Markham, ON L3R 4T5  
T: 416 987 6181 | 905 940 6181  
www.coleengineering.ca

**EVENDALE DEVELOPMENTS LTD.**  
BROCK STREET DEVELOPMENT  
HERREMA BOULEVARD  
STA. 1+000.00 TO STA. 1+163.25

DESIGNED BY: PS DATE: DECEMBER 2018 CHECKED BY: \_\_\_\_\_  
DRAWN BY: ZK PROJECT No. 2017-0569 DRAWING No. PP-01  
SCALE: HORIZ. 1:500 VERT. 1:100

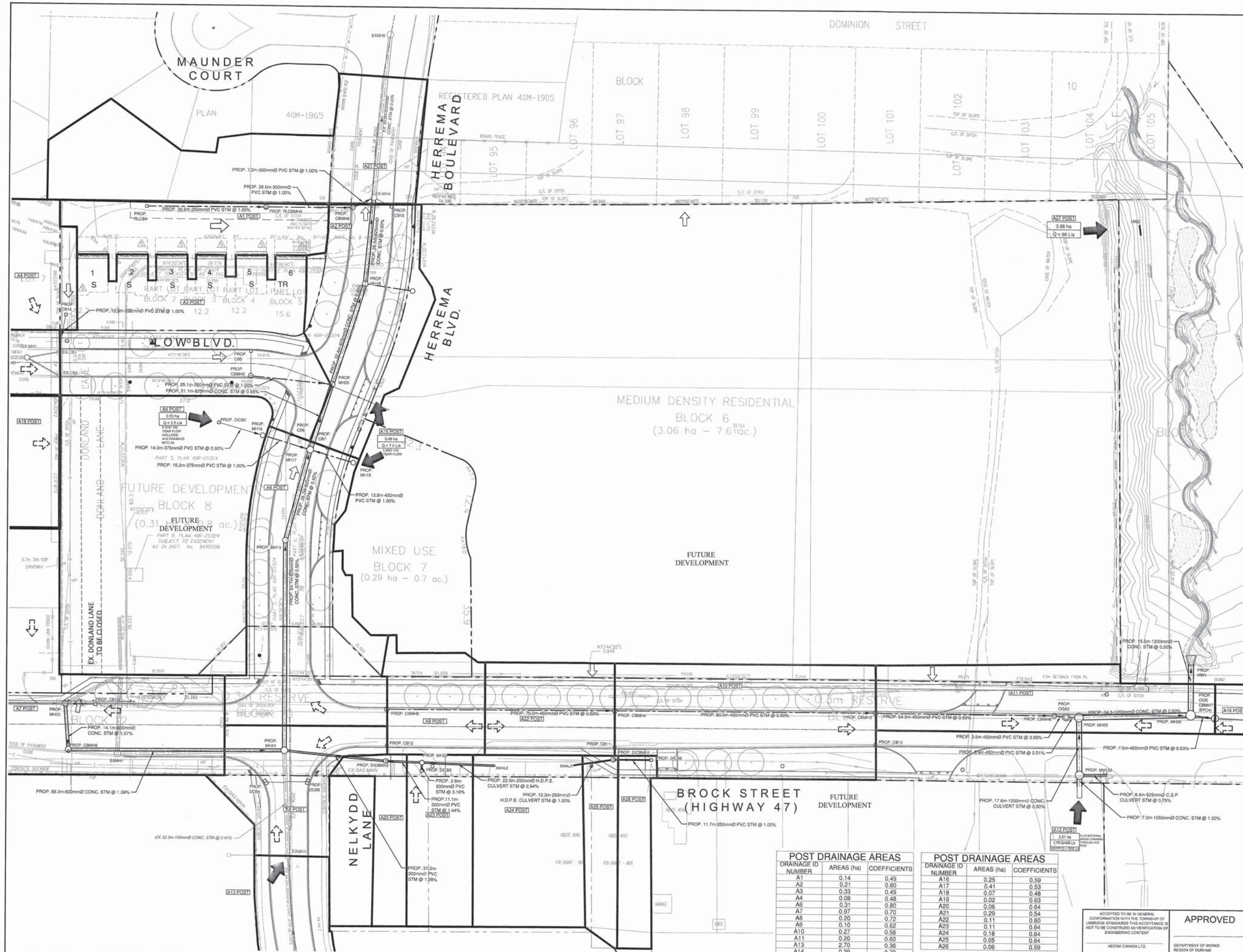

**LEGEND**

- PROPERTY LINE
- STORM DRAINAGE AREA
- STORM DRAINAGE ID
- STORM DRAINAGE AREA (ha) EXTERNAL
- STORM FLOW L/S
- MAJOR FLOW
- EXISTING MAJOR FLOW
- MINOR FLOW
- PROPOSED STORM MANHOLE
- PROPOSED STORM CATCH BASIN MANHOLE
- PROPOSED CATCH BASIN
- PROPOSED DOUBLE CATCH BASIN
- EXISTING MANHOLE
- EXISTING CATCH BASIN
- PROPOSED STORM SEWER
- EXISTING STORM SEWER

**3.06 ha**  
Q = 96 L/s

**2.61 ha**  
Q = 164.3L/s

**SURVEYOR INFORMATION**

J.D. BARNES LIMITED  
110 SCOTIA COURT, #40  
WHITBY, ON L1M 1W7  
PHONE: (905) 723-1212  
FAX: (905) 723-4234

H.F. GRANDER CO. LIMITED  
ONARIO LAND SURVEYOR  
1575 HIGHWAY 7A WEST, UNIT 2A  
PORT PERRY, ON L4A 1A6  
PHONE: (905) 965-3000  
FAX: (905) 965-2247

**BENCHMARK INFORMATION:**  
MINISTRY OF TRANSPORTATION OF ONTARIO PRECISE BENCHMARK N° 0081978487 (AKA 778487), TWO STOREY RED BRICK HOUSE ON SOUTH SIDE OF HIGHWAY 47 (BROCK STREET) IN THE TOWN OF UXBRIDGE, 118.9m EAST OF MARLETTA STREET, 18.4m WEST OF FRANKLIN STREET AND 15.9m SOUTH OF THE CENTRELINE OF HIGHWAY 47. TABLET IS SET HORIZONTALLY IN THE EAST FACE OF CONCRETE FOUNDATION, 3.9m SOUTH OF NORTHEAST CORNER, 30cm ABOVE GROUND LEVEL, AND 34cm BELOW BRICKWORK. ELEVATION = 274.359m (GEODETTIC)

NO.	REVISION	DATE	BY
8	ISSUED FOR CONSTRUCTION	JAN 16, 2020	PS
7	FOR APPROVAL	DEC 06, 2019	PS
6	REGION AND TOWNSHIP SUBMISSION	OCT 28, 2019	PS
5	LSRCA SUBMISSION	SEPT 13, 2019	PS
4	100% SUBMISSION	JUNE 28, 2019	PS
3	ISSUED FOR LSRCA APPROVAL	JUNE 20, 2019	PS
2	90% SUBMISSION	MAR 25, 2019	PS

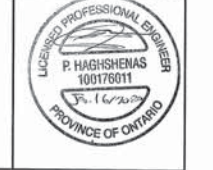

**THE REGIONAL MUNICIPALITY OF DURHAM**

**TOWN OF UXBRIDGE**

**COLE ENGINEERING GROUP LTD.**  
70 Valleywood Drive,  
Markham, ON L3R 4T5  
T: 416 987 6161 | 905 940 6161  
www.coleengineering.ca

**EVENDALE DEVELOPMENTS LTD.**  
BROCK STREET DEVELOPMENT  
UXBRIDGE, ONTARIO

**STORM DRAINAGE AREA PLAN**

DESIGNED BY: PS DATE: JANUARY 2019 CHECKED BY: NG  
DRAWN BY: PS PROJECT NO.: 2017-0569 DRAWING NO.: STM-01  
SCALE: 1:500

**POST DRAINAGE AREAS**

DRAINAGE ID NUMBER	AREAS (ha)	COEFFICIENTS
A1	0.14	0.45
A2	0.21	0.80
A3	0.33	0.45
A4	0.08	0.48
A6	0.31	0.80
A7	0.97	0.70
A8	0.20	0.72
A9	0.10	0.62
A10	0.27	0.56
A11	0.20	0.60
A13	2.70	0.36
A14	0.29	0.70

**POST DRAINAGE AREAS**

DRAINAGE ID NUMBER	AREAS (ha)	COEFFICIENTS
A16	0.25	0.59
A17	0.41	0.53
A18	0.07	0.48
A19	0.02	0.63
A20	0.06	0.54
A21	0.29	0.54
A22	0.11	0.60
A23	0.11	0.64
A24	0.18	0.64
A25	0.05	0.64
A26	0.06	0.59

ACCEPTED TO BE IN GENERAL CONFORMANCE WITH THE TOWNSHIP OF UXBRIDGE STANDARDS THIS ACCEPTANCE IS NOT TO BE CONSIDERED AS VERIFICATION OF ENGINEERING CONTENT

**APPROVED**

AECOM CANADA LTD.  
DATE: \_\_\_\_\_

DEPARTMENT OF WORKS  
REGION OF DURHAM  
DATE: \_\_\_\_\_





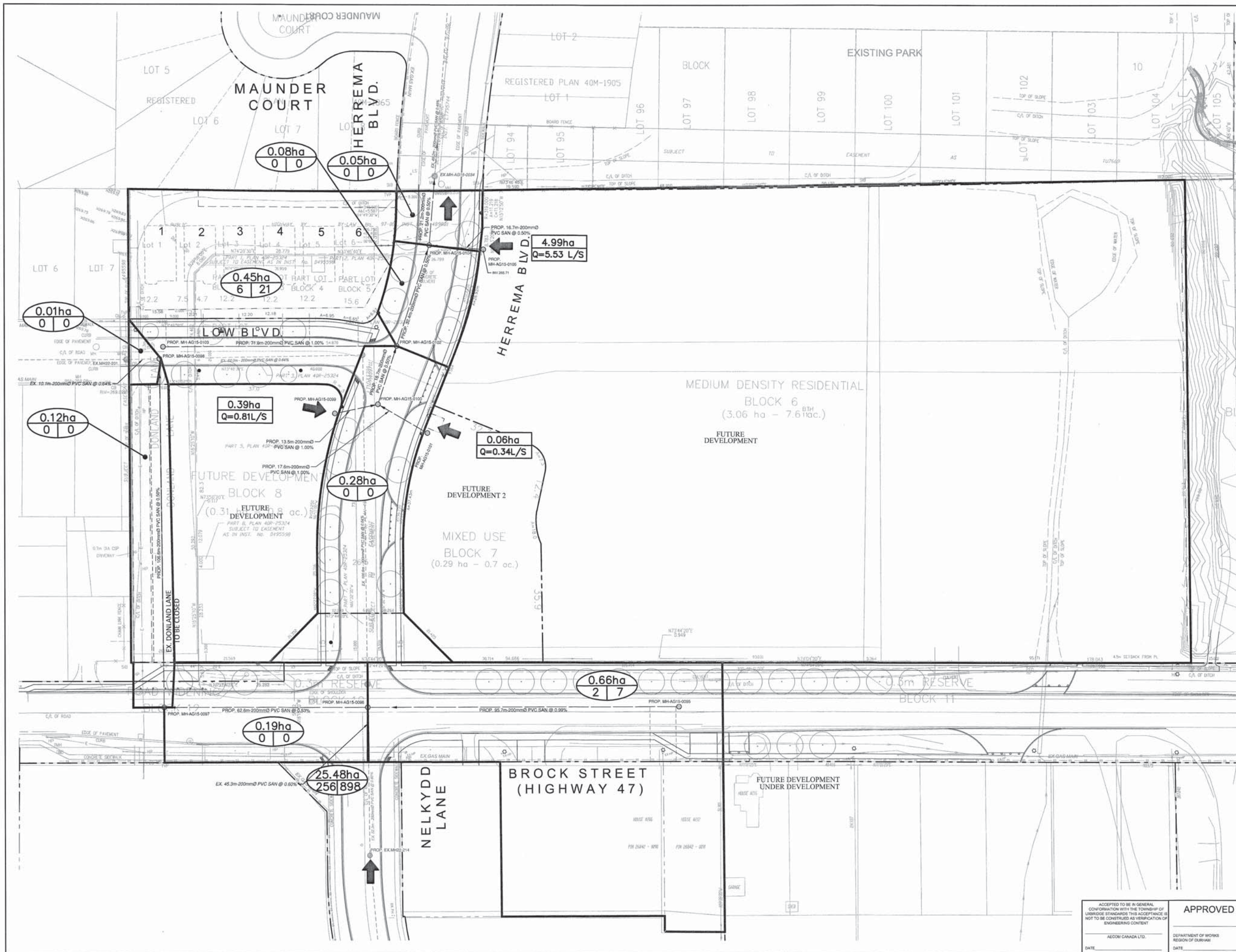

**LEGEND**

PROPERTY LINE  
 POST-DEVELOPMENT SANITARY DRAINAGE AREA  
 DRAINAGE AREA (ha)  $\frac{\text{Area ha}}{\text{Unit} \times \text{PPU}}$   
 TOTAL UNITS  $\frac{\text{Area ha}}{\text{Q}} \times \text{L/S}$   
 TOTAL SANITARY FLOW  $Q = X \text{ L/S}$   
 GRAVITY FLOW DIRECTION  
 PROPOSED SANITARY MANHOLE  
 PROPOSED SANITARY  
 EXISTING SANITARY  
 SANITARY SERVICE CONNECTION

**SURVEYOR INFORMATION**

J.D. BARNES LIMITED  
 115 SCOTIA COURT, #40  
 WILTON, ON L7M 8Y7  
 PHONE: (905) 723-2122  
 FAX: (905) 723-4234

H.F. GRANDER Co. LIMITED  
 ONTARIO LAND SURVEYOR  
 1515 HIGHWAY 7A WEST, UNIT 2A  
 RICHMOND HILL, ON L4B 1A4  
 PHONE: (905) 885-1800  
 FAX: (905) 885-2347

**BENCHMARK INFORMATION:**  
 MINISTRY OF TRANSFORMATION OF ONTARIO PRECISE BENCHMARK N° 0081777487 (AKA 779487), TWO STOREY RED BRICK HOUSE ON SOUTH SIDE OF HIGHWAY 47 (BROCK STREET) IN THE TOWN OF UXBRIDGE, 118.8m EAST OF MARSETTA STREET, 18.4m WEST OF FRANKLIN STREET AND 15.8m SOUTH OF THE CENTRELINE OF HIGHWAY 47. TABLE IS SET HORIZONTALLY IN THE EAST FACE OF CONCRETE FOUNDATION, 3.8m SOUTH OF NORTHEAST CORNER, 30cm ABOVE GROUND LEVEL AND 34cm BELOW BRICKWORK. ELEVATION = 274.359m (GEOIDETIC)

NO.	REVISION	DATE	BY
8	ISSUED FOR CONSTRUCTION	JAN 16, 2020	PS
7	FOR APPROVAL	DEC 06, 2019	PS
6	REGION AND TOWNSHIP SUBMISSION	OCT 28, 2019	PS
5	LSRCA SUBMISSION	SEPT 13, 2019	PS
4	100% SUBMISSION	JUNE 28, 2019	PS
3	ISSUED FOR LSRCA APPROVAL	JUNE 20, 2019	PS
2	90% SUBMISSION	MAR 25, 2019	PS



**THE REGIONAL MUNICIPALITY OF DURHAM**

**TOWN OF UXBRIDGE**

**COLE ENGINEERING GROUP LTD.**  
 70 Valleywood Drive,  
 Markham, ON L3R 4T5  
 T: 416 967 6161 | 905 940 6161  
 www.coleengineering.ca

**EVENDALE DEVELOPMENTS LTD.**  
 BROCK STREET DEVELOPMENT  
 UXBRIDGE, ONTARIO

ACCEPTED TO BE IN GENERAL CONFORMANCE WITH THE TOWNSHIP OF UXBRIDGE STANDARDS THIS ACCEPTANCE IS NOT TO BE CONSTRUED AS VERIFICATION OF ENGINEERING CONTENT

APPROVED

ACCOM CANADA LTD.  
 DEPARTMENT OF WORKS  
 REGION OF DURHAM

**SANITARY DRAINAGE AREA PLAN**

DESIGNED BY:	PS	DATE:	JANUARY 2019	CHECKED BY:	NG
DRAWN BY:	PS	PROJECT No.:	2017-0569	DRAWING No.:	SAN-01
SCALE:	1:500				





### TOWNSHIP OF UXBRIDGE

ENGINEERING AND PUBLIC WORKS DEPARTMENT

### SANITARY SEWER DESIGN SHEET

RESIDENTIAL DEVELOPMENT

Sheet: 1 of 1  
Prepared By: PS  
Date: 1-Apr-19  
Project No.: UD17-0569

Residential Population Density:  
 Single Dwelling Units: 3.5 Persons/Unit  
 q = average daily flow per person  
 M = Peaking Factor (Residential)  
 M = 1 + 14/(4+P<sup>0.5</sup>)  
 where P = population in 1000's

Townhouses: 3.0 Persons/Unit  
 L/d

Infiltration: 22,500 L/ha/day  
 Commercial: 180,000 L/g/day  
 Q (p) = peak population flow (L/s)  
 Q (I) = peak infiltration flow (L/s)  
 Q (C) = peak flow from commercial area (L/s)  
 Q (d) = Total Peak flow (L/s)

LOCATION	MANHOLE		No. of Units	P.P.U.	Pop	Acc Pop	Avg Day Flow (L/s)	RESIDENTIAL						COMMERCIAL		IND. & INST.		Total		ACCUM		SEWER DESIGN										Remarks
	From MH	To MH						Peaking Factor M	Peak Pop. Flow (L/s)	Sect Area (ha)	Accum Area (ha)	Infiltr. Flow (L/s)	Res. Flow (L/s)	Area (ha)	Peak Flow (L/s)	Area (ha)	Peak Flow (L/s)	Peak Flow (L/s)	Peak Flow (L/s)	Pipe Diameter (mm)	Pipe Material	Roughness	Grade (%)	Length (m)	Capacity (L/s)	% of Design Capacity	Full Velocity (m/s)	Actual Velocity (m/s)				
FUTURE DEVELOPMENT 2	MH-AG15-0101	MH-AG15-100	5	2.5	13	13	0.05	3.80	0.20	0.08	0.06	0.02	0.22	0.08	0.13	0.00	0.00	0.34	0.34	200	PVC	0.013	1.00	17.3	32.80	1.0%	1.04	0.33				
HERREMA BLVD.	MH-AG15-0099	MH-AG15-100	0	0	0	0	0.00	3.80	0.00	0.00	0.00	0.00	0.00	0.39	0.81	0.00	0.00	0.81	0.81	200	PVC	0.013	1.00	13.5	32.80	2.5%	1.04	0.42				
HERREMA BLVD.	MH-AG15-100	MH-AG15-0102	0	0	0	0	0.00	3.80	0.00	0.28	0.28	0.07	0.07	0.00	0.00	0.00	0.07	1.23	200	PVC	0.013	0.50	18.7	23.19	5.3%	0.74	0.16					
HERREMA BLVD.	MH-AG15-0103	MH-AG15-0102	6	3.5	21	21	0.09	3.80	0.34	0.45	0.45	0.12	0.45	0.00	0.00	0.00	0.45	0.45	200	PVC	0.013	1.00	71.9	32.80	1.4%	1.04	0.36					
HERREMA BLVD.	MH-AG15-0102	MH-AG15-0104	0	0	0	34	0.14	3.80	0.54	0.08	0.87	0.23	0.76	0.00	0.00	0.00	0.76	2.44	200	PVC	0.013	0.50	32.4	23.19	10.5%	0.74	0.33					
HERREMA BLVD.	MH-AG15-0105	MH-AG15-0104	88	3	264	264	1.11	3.80	4.23	4.99	4.99	1.30	5.53	0.00	0.00	0.00	5.53	5.53	200	PVC	0.013	0.50	16.7	23.19	23.8%	0.74	0.60					
HERREMA BLVD.	MH-AG15-0104	EX-MH-AG15-0034	0	0	0	298	1.25	3.80	4.78	0.05	5.91	1.54	6.30	0.00	0.00	0.00	6.30	14.27	200	PVC	0.013	0.50	21.2	23.19	61.5%	0.74	0.62					
EASEMENT																																
BROOK STREET	MH13A	MH-AG15-0096	2	3.5	7	7	0.03	3.80	0.11	0.66	0.66	0.17	0.28	0.00	0.00	0.00	0.28	0.28	200	PVC	0.013	1.00	94.7	32.80	0.9%	1.04	0.30					
NELKYDD LANE	EX-MH22-214	MH-AG15-0096	256	0	898	898	3.78	3.80	14.38	25.48	25.48	6.64	21.01	0.00	0.00	0.00	21.01	21.01	200	PVC	0.013	0.60	45.3	25.41	82.7%	0.81	0.90					
BROOK STREET	MH-AG15-0096	MH-AG15-0097	0	0	0	905	3.81	3.80	14.49	0.19	25.67	6.68	21.17	0.00	0.00	0.00	21.17	21.46	200	PVC	0.013	0.53	62.6	23.88	89.9%	0.76	0.86					
EASEMENT	MH-AG15-0097	MH-AG15-0098	0	0	0	905	3.81	3.80	14.49	0.12	25.79	6.72	21.20	0.00	0.00	0.00	21.20	21.49	200	PVC	0.013	0.50	106.6	23.19	82.7%	0.74	0.84					
LOW BLVD.	MH-AG15-0098	EX-MH22-201	0	0	0	905	3.81	3.80	14.49	0.01	25.80	6.72	21.21	0.00	0.00	0.00	21.21	21.49	200	PVC	0.013	0.64	10.6	26.24	81.9%	0.84	0.93					

S:\2017 Projects\IC\2017-0569 Evendale BrockStreet\_Uxbridge\300-Design-Engineering\304-Calcs\Sanitary



#### LEGEND

#### SURVEYOR INFORMATION

JD BARRER LIMITED  
 110 SCOTIA COURT, #40  
 WILTON, ON L1M 8Y7  
 PHONE: (905) 723-1212  
 FAX: (905) 723-4234

H.F. GRANDER Co. LIMITED  
 ONTARIO LAND SURVEYOR  
 1375 HIGHWAY 7A WEST, UNIT 2A  
 PORT PERRY, ON L9L 1M6  
 PHONE: (905) 985-9600  
 FAX: (905) 985-9247

BENCHMARK INFORMATION:  
 MINISTRY OF TRANSPORTATION OF ONTARIO PRECISE BENCHMARK N° 00819778487 (AKA 778487), TWO STOREY RED BRICK HOUSE ON SOUTH SIDE OF HIGHWAY 47 (BROCK STREET) IN THE TOWN OF UXBRIDGE, 118.8m EAST OF MARSETTA STREET, 18.4m WEST OF FRANKLIN STREET AND 15.9m SOUTH OF THE CENTRELINE OF HIGHWAY 47. TABLE IS SET HORIZONTALLY IN THE EAST FACE OF CONCRETE FOUNDATION, 3.0m SOUTH OF NORTHEAST CORNER, 30cm ABOVE GROUND LEVEL AND 34cm BELOW BRICKWORK. ELEVATION = 274.359m (GEOIDETIC)

8	ISSUED FOR CONSTRUCTION	JAN 16, 2020	PS
7	FOR APPROVAL	DEC 06, 2019	PS
6	REGION AND TOWNSHIP SUBMISSION	OCT 28, 2019	PS
5	LSRCA SUBMISSION	SEPT 13, 2019	PS
4	100% SUBMISSION	JUNE 28, 2019	PS
3	ISSUED FOR LSRCA APPROVAL	JUNE 20, 2019	PS
2	90% SUBMISSION	MAR 25, 2019	PS

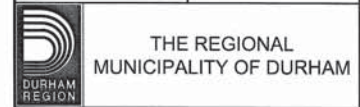

TOWN OF UXBRIDGE



EVENDALE DEVELOPMENTS LTD.  
BROCK STREET DEVELOPMENT  
UXBRIDGE, ONTARIO

#### SANITARY DESIGN SHEET

ACCEPTED TO BE IN GENERAL CONFORMANCE WITH THE TOWNSHIP OF UXBRIDGE STANDARDS THIS ACCEPTANCE IS NOT TO BE CONSTRUED AS VERIFICATION OF ENGINEERING CONTENT

ACCOM CANADA LTD.  
 DEPARTMENT OF WORKS  
 REGION OF DURHAM

APPROVED

DESIGNED BY: PS	DATE: JANUARY 2019	CHECKED BY: NG
DRAWN BY: PS	PROJECT No.: 2017-0569	DRAWING No.: SAN-02
SCALE: 1:500		



## **APPENDIX B**

### **- Watermain Analysis**



## Table F1 Available Fire Flow Calculations

Project:	Prop. 6-Storey Residential Condominium		
Client:	Evendale Developments Ltd.		
Outlet diameter:	2.5 in, one port	Location:	Low Boulevard & Donland Lane
Static pressure:	85 psi	Date of Test:	27-Oct-17
Resid. pressure:	74 psi, one port	Operator:	Cole Engineering

• **Observed Flow**  $Q_F = 29.83 \times C \times (d^2) \times (p^{0.5})$

where C = 0.90 Coefficient  
d = 2.50 in, Outlet diameter  
p = 56.00 psi, Pitot Pressure

⇒  $Q_F = 1,233$  USGPM  
 $4,669$  L/min

• **Available Flow**  $Q_R = Q_F \times (h_R^{0.54}) / (h_F^{0.54})$

where  $h_F = 11.00$  psi, Pressure difference, static to measured residual  
 $h_R = 65.00$  psi, Pressure difference, static to required residual  
Required = 20.00 psi

⇒  $Q_F = 3,219$  USGPM  
 $12,185$  L/min

## Table F2 Required Fire Flow Calculations

Project: **Prop. 6-Storey Residential Condominium**

Client: **Evendale Developments Ltd.**

<b>• Base Flow</b>	$F_B = 220 \times C_C \times A^{0.5}$	
	where $C_C = 0.60$	from Table F3
	$A = 2479.5 \text{ m}^2$	from Table F3
	$\Rightarrow F_B = 6,573 \text{ L/min}$	
	$7,000 \text{ L/min}$	rounded to nearest 1,000 L/min
<b>• Occupancy Factor</b>	$C_O = 15\%$	from Table F3
	$F_O = F_B + (F_B \times C_O)$	
	$= 8,050 \text{ L/min}$	
<b>• Sprinkler Factor</b>	$C_S = -30\%$	from Table F3
	$f_S = F_O \times C_S$	
	$= -2,415 \text{ L/min}$	
<b>• Exposure Factor</b>	$C_E = 20\%$	from Table F3
	$f_E = F_O \times C_E$	
	$= 1,610 \text{ L/min}$	
<b>• Total Required Flow</b>	$F = F_O + f_S + f_E$ $= 7,245 \text{ L/min}$ $= 7,000 \text{ L/min}$	rounded to nearest 1,000 L/min

### Table F3 Building Area and Coefficients

Project: **Prop. 6-Storey Residential Condominium**  
 Client: **Evendale Developments Ltd.**

• **Area of Building** 2,480 m<sup>2</sup>

The total floor area in square metres (including all storeys, but excluding basements at least 50 percent below grade) in the building being considered.

*For fire-resistive buildings, consider the two largest adjoining floors plus 50 percent of each of any floors immediately above them up to eight, when the vertical openings are inadequately protected.*

*If the vertical openings and exterior vertical communications are properly protected (one hour rating), consider only the area of the largest floor plus 25 percent of each of the two immediately adjoining floors.*

• **Construction Coefficient** floors. 0.60 ⇔

1.50	Wood Frame
1.00	Ordinary Construction
0.80	Non-Combustible
0.70	Fire Resistive (<2 hrs)
<b>0.60</b>	<b>Fire Resistive (&gt;2 hrs)</b>

• **Occupancy Coefficient**  $C_O =$  15% ⇔

-25%	Non-Combustible
<b>-15%</b>	<b>Limited Combustible</b>
0%	Combustible
15%	Free Burning
25%	Rapid Burning

• **Sprinkler Coefficient**  $C_S =$  -30% ⇔

<b>-30%</b>	<b>NFPA 13 standard</b>
-40%	+ fully supervised
-50%	+ std water supply

• **Exposure Coefficient**  $C_E =$  20% ⇔

25%	0 - 3m separation
20%	3.1- 10m separation
15%	10.1- 20m separation
10%	20.1- 30m separation
5%	> 30m separation
<i>percentages counted per side, max 75%</i>	

N	> 30m	5%
S	> 30m	5%
E	> 30m	5%
W	> 30m	5%

HYDRANT FLOW TEST FORM

Test # 2



Project No: 2017-0569

Date: October 27, 2017

Site Location: Rock St. E  
Uxbridge, On.

Hydrants Opened by: Durham water

Tested By: Gordon H, Ryan B.

1) Required photos:

- Site Id & Date
- Condition of Flow Hydrant
- Location Overview
- Condition of Residual Hydrant
- Other

2) Test Data

Time of Test: 1100

Location of Test: (Flow) At SW corner of Low Blvd + Donland Ln.

(Residual) In front of 6-8 Low Blvd, south side

Main Size: 150mm

Static Pressure: 85psi

	Number of Outlets & Orifice Size	Pitot Pressure	Flow (USGPM)	Residual Pressure
1	1 x 2.5"	56	1250	74
2	2 x 2.5"	32	1900	60
3				
4				

3) Calculations

$Q = 29.83 \text{ cd}^2 \sqrt{p}$

$$Q_1 = (29.83)(0.9)(2.5")^2 \sqrt{56}$$

$$= 1255.65$$

$Q_1 = \sim 1250 \text{ USGPM}$

$$Q_2 = 2(29.83)(0.9)(2.5")^2 \sqrt{32}$$

$$= 1899.37$$

$Q_2 = \sim 1900 \text{ USGPM}$

Where c- coefficient of discharge (1 in smooth pipe)  
d- pipe diameter (inches)  
p- pitot reading (psi)  
Q- flow (USGPM)

**Note: Hydrants tested according to NFPA 291: Recommended Practice for Fire Flow Testing and Marking of Hydrants**



4) Plot

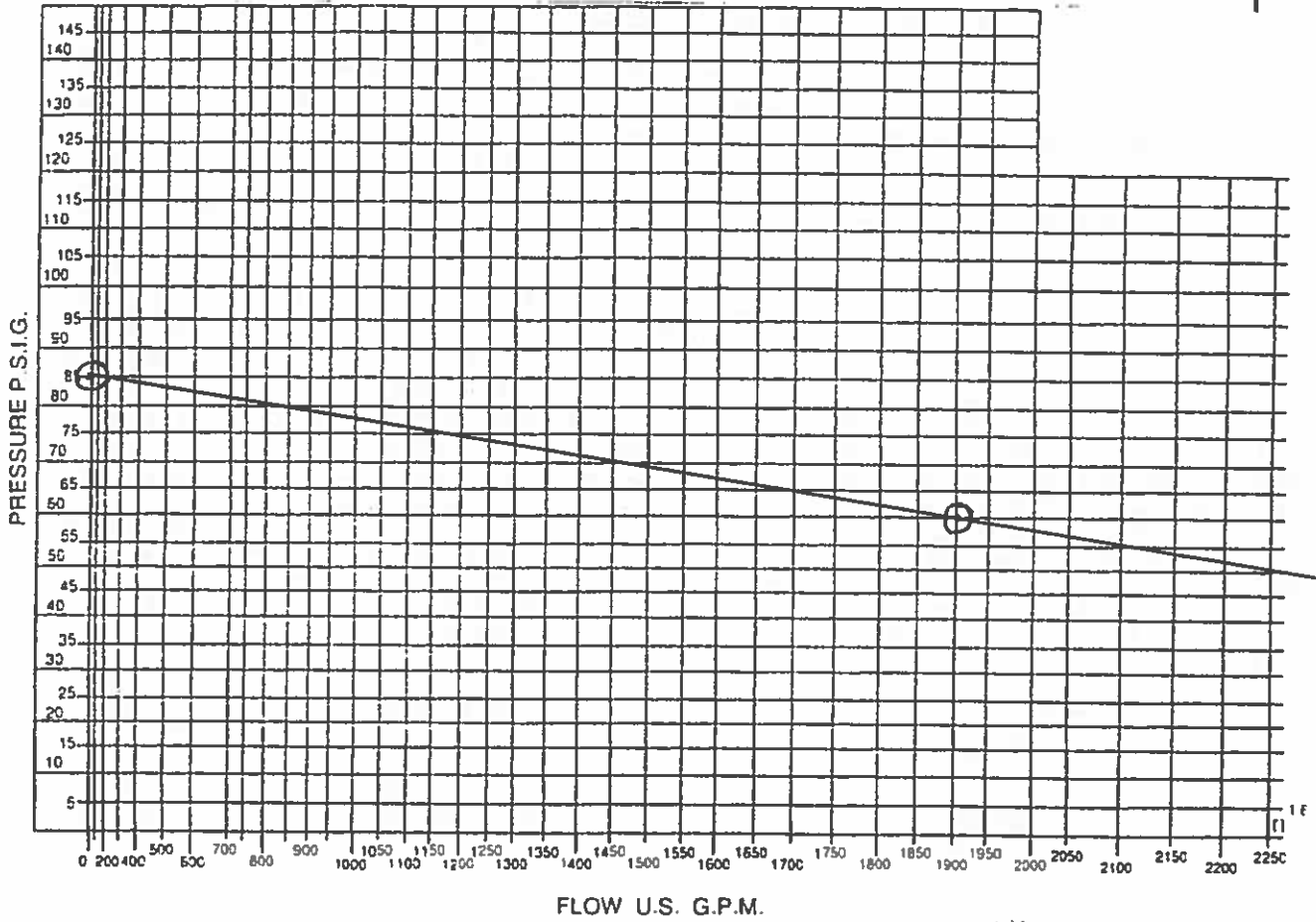

$$Q_{avail} @ 20 \text{ psi} = Q_t \left( \frac{P_s - P_A}{P_s - P_R} \right)^{0.54}$$

$$= 1898.37 \left( \frac{85 - 20}{85 - 60} \right)^{0.54}$$

$$= 3180.29$$

Q<sub>avail</sub> = ~ 3200 USGPM

5) Site sketch & Comments

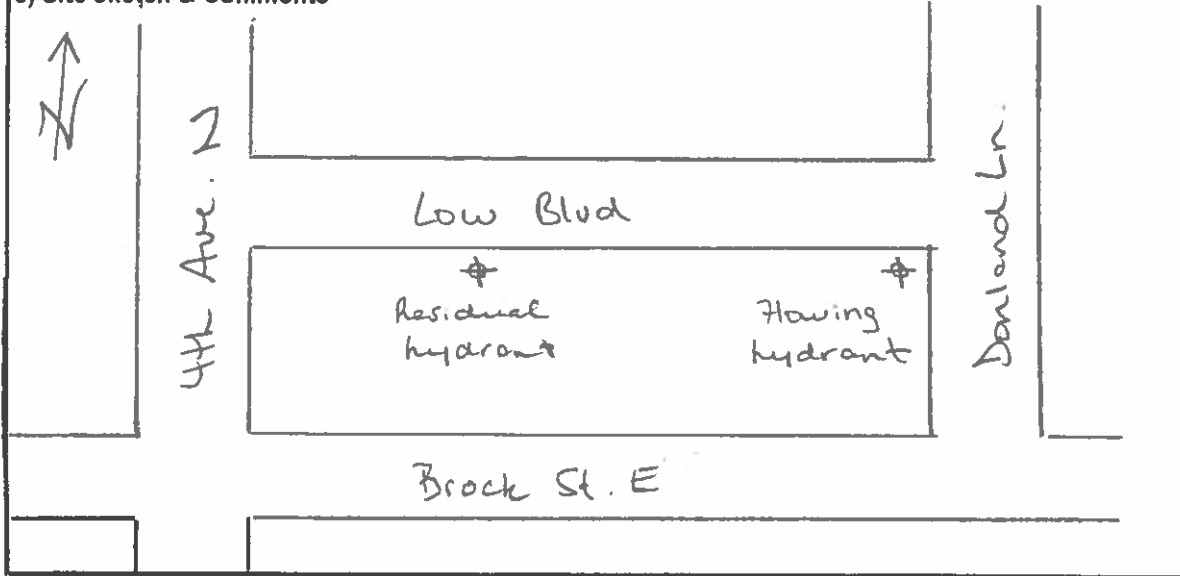



## **APPENDIX C**

### **- Stormwater Management**



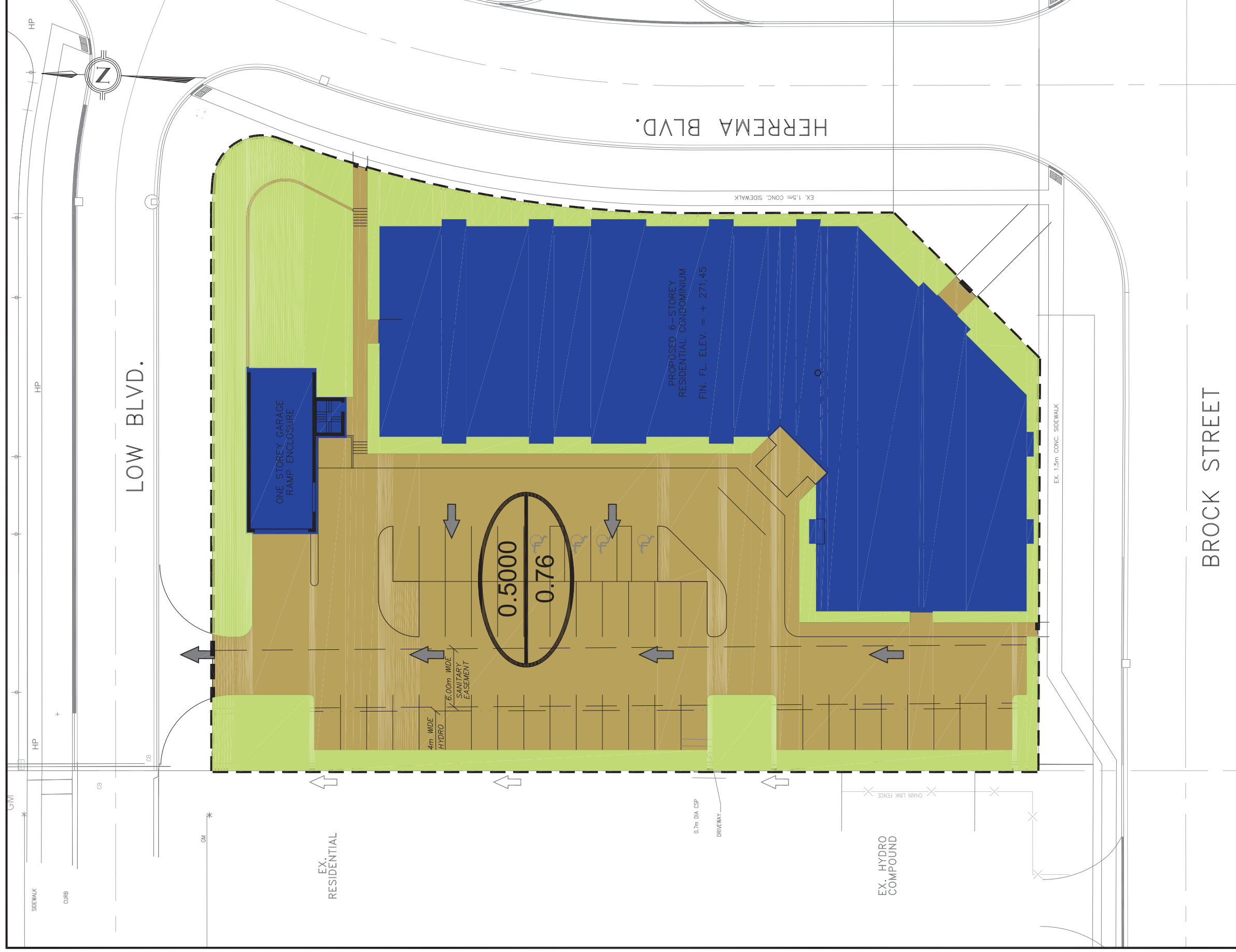

SITE AREA (POST DEVELOPMENT)			
DESCRIPTION	AREA (Ha.)	RUNOFF COEFF.	
ROOFTOP AREA	0.1653	0.90	
ASPHALT/CONC.	0.2294	0.90	
LANDSCAPE AREA	0.1053	0.25	
	0.5000	0.76	



**TABLE C1 Roof Drain Sizing Calculation**

Rise						
Notch Area m <sup>2</sup>	51		102		152	
	Discharge	Water Depth	Discharge	Water Depth	Discharge	Water Depth
	LPM	mm	LPM	mm	LPM	mm
232	66	73.5	82	91.5	97.5	109
465	77.5	86.5	93	104	111.5	124.5
697	84	94	100	112	120.5	134.5
929	86.5	96.5	104.5	117	127.5	142
	LPS		LPS		LPS	
232	1.10		1.37		1.63	
465	1.29		1.55		1.86	
697	1.40		1.67		2.01	
929	1.44		1.74		2.13	

**Release Rate**

Roof Area                      0.1653            ha  
 Release Rate                 42                    L/s/ha

Total	<b>6.94</b>	L/s
-------	-------------	-----

**Roof Drain Sizing**

Drain Type                      465  
 Depth of Ponding             0.1245            m  
 Number of Drains             4  
 Number of Notches per Drain   1  
 Flow Rating per Notch        1.86                L/s

**Total Flow from Drain Type 465**                      **7.44**            L/s

**Total Flow from all Drains**                              **7.44**            L/s

**Total Number of Drains**                                **4**

Table C2



On-Site Storage  
Calculator

**Uxbridge 100-Year**

Project: Herrema/Block  
Project No.: 20-028  
By: KL  
Date: 24-Jul-20

Location: **Rooftop Area**

A = 0.1653 ha  
Composite C = 0.90  
*i*-5y (Allowable) = 107.01 mm/hr  
*Q* Allowable = 0.0074 m<sup>3</sup>/s  
*Q* Actual = 0.0074 m<sup>3</sup>/s

	A	B
<i>i</i> <sub>5</sub>	904	-0.788
<i>i</i> <sub>100</sub>	1799	-0.81

*i* =  $A \times (tc+5)^B$ , *tc* in min.

<i>t</i> <sub>c</sub> (min)	<i>i</i> <sub>100</sub> (mm/hr)	<i>Q</i> <sub>100</sub> (m <sup>3</sup> /s)	<i>Q</i> <sub>stored</sub> (m <sup>3</sup> /s)	Peak Volume (m <sup>3</sup> )
10	200.631	0.0829	0.075	45.282
11	190.412	0.0787	0.071	47.023
12	181.287	0.0749	0.067	48.583
13	173.085	0.0715	0.064	49.988
14	165.669	0.0685	0.061	51.259
15	158.927	0.0657	0.058	52.413
16	152.768	0.0631	0.056	53.464
17	147.119	0.0608	0.053	54.424
18	141.916	0.0586	0.051	55.303
19	137.107	0.0567	0.049	56.110
20	132.648	0.0548	0.047	56.852
21	128.500	0.0531	0.046	57.535
22	124.631	0.0515	0.044	58.164
23	121.013	0.0500	0.043	58.745
24	117.622	0.0486	0.041	59.281
25	114.436	0.0473	0.040	59.776
26	111.437	0.0461	0.039	60.233
27	108.607	0.0449	0.037	60.656
28	105.934	0.0438	0.036	61.046
29	103.403	0.0427	0.035	61.407
30	101.003	0.0417	0.034	61.739
31	98.725	0.0408	0.033	62.046
32	96.558	0.0399	0.032	62.328
33	94.494	0.0390	0.032	62.587
34	92.527	0.0382	0.031	62.825
35	90.649	0.0375	0.030	63.043
36	88.854	0.0367	0.029	63.242
37	87.136	0.0360	0.029	63.423
38	85.491	0.0353	0.028	63.588
39	83.914	0.0347	0.027	63.736
40	82.400	0.0341	0.027	63.869
41	80.946	0.0335	0.026	63.987 ***
42	79.548	0.0329	0.025	64.092



Table C3



On-Site Storage  
Calculator

Uxbridge 100-Year

Project: Herrema/Block  
Project No.: 20-028  
By: KL  
Date: 24-Jul-20

Location: **Parking Area**

A = 0.3347 ha  
Composite C = 0.70  
 $i_{-5y}$  (Allowable) = 107.01 mm/hr  
 $Q_{Allowable}$  = 0.0035 m<sup>3</sup>/s  
 $Q_{Actual}$  = 0.0035 m<sup>3</sup>/s

	A	B
$i_{15}$	904	-0.788
$i_{100}$	1799	-0.81

$i = A \times (tc+5)^B$ , tc in min.

=7.44 L/s from controlled rooftop area

$t_c$ (min)	$i_{100}$ (mm/hr)	$Q_{100}$ (m <sup>3</sup> /s)	$Q_{stored}$ (m <sup>3</sup> /s)	Peak Volume (m <sup>3</sup> )
10	200.631	0.1380	0.135	80.707
11	190.412	0.1314	0.128	84.388
12	181.287	0.1254	0.122	87.784
13	173.085	0.1201	0.117	90.936
14	165.669	0.1153	0.112	93.877
15	158.927	0.1109	0.107	96.633
16	152.768	0.1069	0.103	99.228
17	147.119	0.1032	0.100	101.680
18	141.916	0.0998	0.096	104.004
19	137.107	0.0967	0.093	106.214
20	132.648	0.0938	0.090	108.321
21	128.500	0.0911	0.088	110.336
22	124.631	0.0886	0.085	112.267
23	121.013	0.0862	0.083	114.121
24	117.622	0.0840	0.080	115.904
25	114.436	0.0819	0.078	117.623
26	111.437	0.0800	0.076	119.283
27	108.607	0.0781	0.075	120.888
28	105.934	0.0764	0.073	122.442
29	103.403	0.0747	0.071	123.949
30	101.003	0.0732	0.070	125.412
31	98.725	0.0717	0.068	126.835
32	96.558	0.0703	0.067	128.218
33	94.494	0.0689	0.065	129.566
34	92.527	0.0677	0.064	130.881
35	90.649	0.0664	0.063	132.163
36	88.854	0.0653	0.062	133.416
37	87.136	0.0641	0.061	134.640
38	85.491	0.0631	0.060	135.838
39	83.914	0.0621	0.059	137.011
40	82.400	0.0611	0.058	138.160
41	80.946	0.0601	0.057	139.286 ***
42	79.548	0.0592	0.056	140.391

# TEMPEST Product Submittal Package



**Date: October 9, 2020**

**Customer: Masongsong Associates**

**Contact: Ken Lo**

**Location: Toronto**

**Project Name: Herrema and Brock Street**



# Tempest LMF ICD Sq Shop Drawing

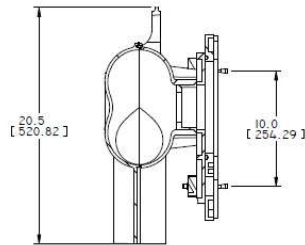
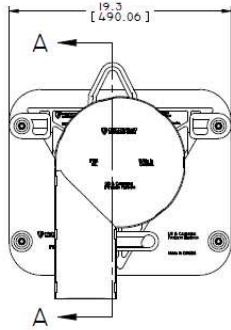
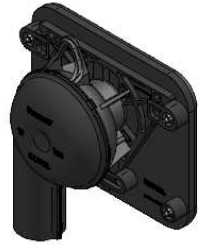
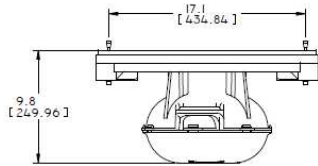

SECTION A-A

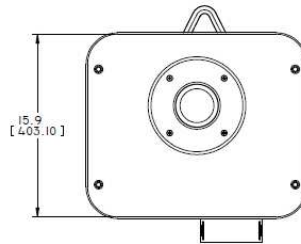

TOLERANCES: UNLESS OTHERWISE SPECIFIED:		<b>IPEX TECHNOLOGIES INC.</b> Product development equipment 7 Place du Commerce, Suite 202 44100 Gagny, France, CE, UE, EU Canada: Tel: 514 749 2200 www.ipex.com	
FRA	+0.040 / -0.040		
FIN	+0.020 / -0.020	PROJECTION	1ST ANGLE
F.001	+0.020 / -0.020	UNITS	in (mm)
F.002	+0.020 / -0.020	DATE	2011-07-27
F.003	+0.020 / -0.020	DESIGN BY	HE. MC-MARTIN
F.004	+0.020 / -0.020	DATE	2011-07-27
F.005	+0.020 / -0.020	REV	B 1/8
F.006	+0.020 / -0.020	SCALE	1:1
F.007	+0.020 / -0.020	DRAWING NUMBER	SM714-PAD00R03
F.008	+0.020 / -0.020	REV	3
F.009	+0.020 / -0.020	SHEET	1 OF 1

### Tempest LMF ICD Flow Curve

**Flow: 3.5 L/s**  
**Head: 1.512 m**

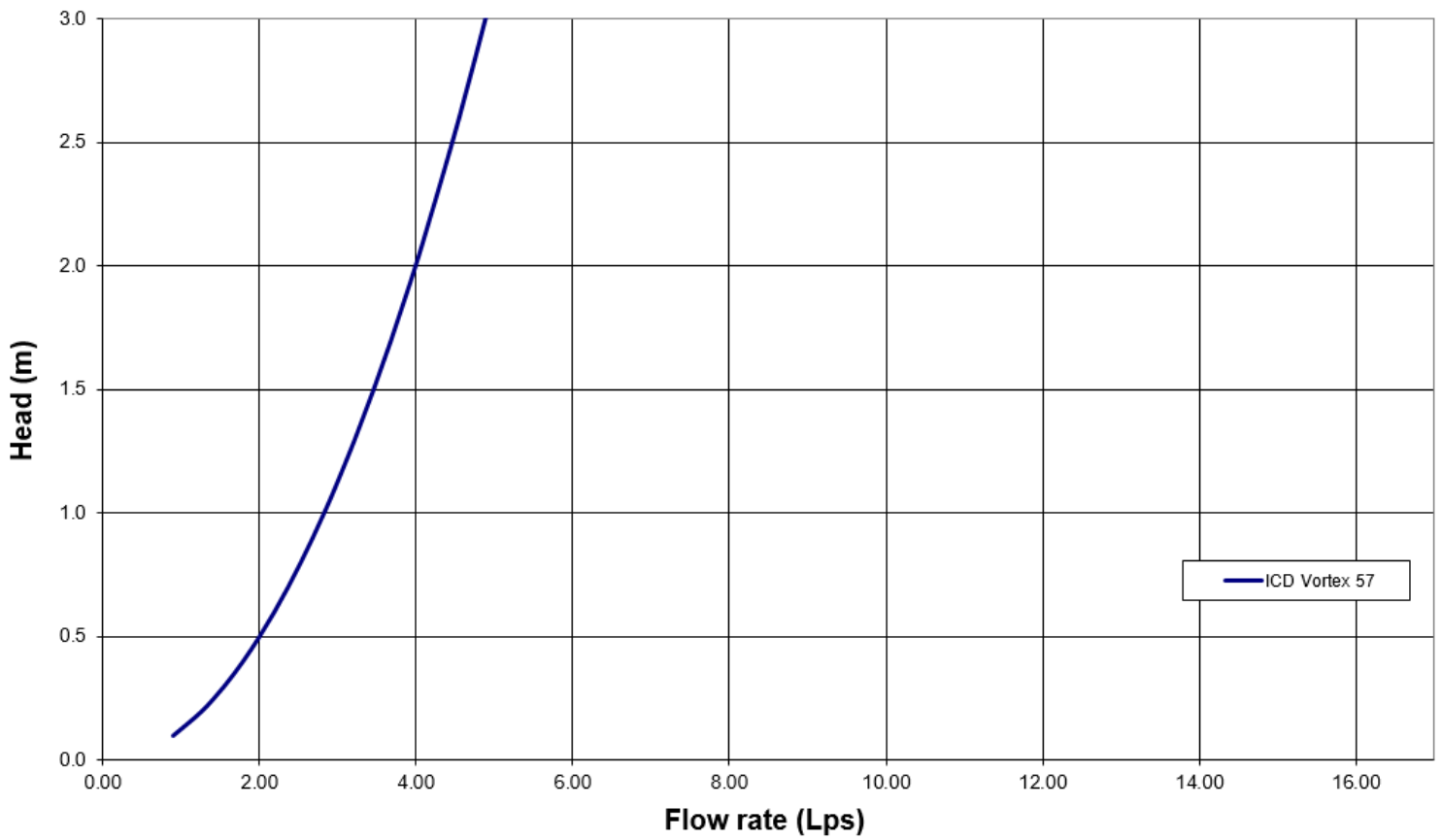

### **Square CB Installation Notes:**

1. Materials and tooling verification:
  - Tooling: impact drill, 3/8" concrete bit, torque wrench for 9/16" nut, hand hammer, level, and marker.
  - Material: (4) concrete anchor 3/8x3-1/2, (4) washers, (4) nuts
2. Use the mounting wall plate to locate and mark the hole (4) pattern on the catch basin wall. You should use a level to ensure that the plate is at the horizontal.
3. Use an impact drill with a 3/8" concrete bit to make the four holes at a minimum of 1-1/2" depth up to 2-1/2". Clean the concrete dust from the holes.
4. Install the anchors (4) in the holes by using a hammer. Put the nuts on the top of the anchors to protect the threads when you will hit the anchors with the hammer. Remove the nuts on the ends of the anchors
5. Install the wall mounting plate on the anchors and screw the nut in place with a maximum torque of 40 N.m (30 lbf-ft). There should be no gap between the wall mounting plate and the catch basin wall.
6. From ground above using a reach bar, lower the device by hooking the end of the reach bar to the handle of the LMF device. Align the triangular plate portion into the mounting wall plate. Push down the device to be sure it has centered in to the wall mounting plate and has created a seal.

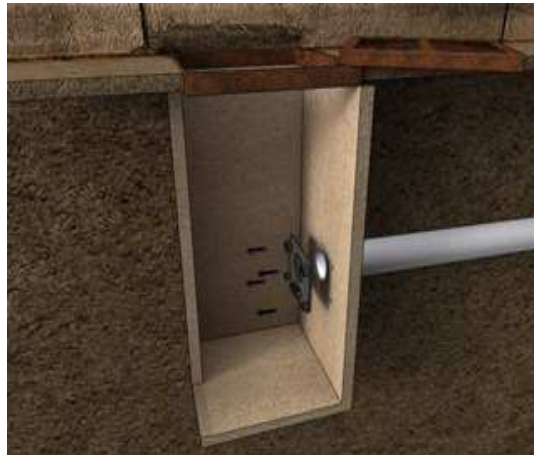
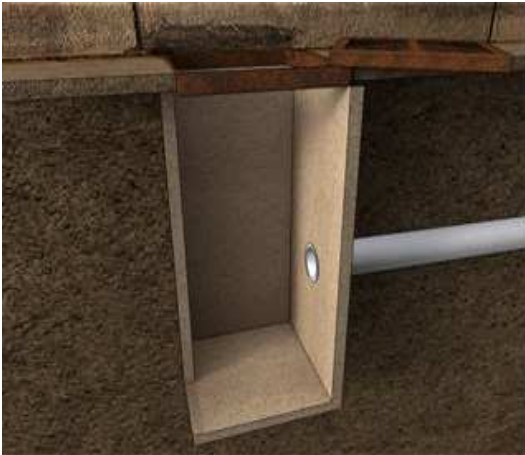

**Round CB Installation Notes:** (Refer to square install notes above for steps 1 , 3, & 4)

2. Use spigot catch basin wall plate to locate and mark the hole (4) pattern on the catch basin wall. You should use a level to ensure that the plate is at the horizontal.
5. Install the CB spigot wall plate on the anchors and screw the 4 nuts in place with a maximum torque of 40 N.m (30 lb-ft). There should be no gap between the CB spigot wall plate and the catch basin wall.
6. Apply solvent cement on the hub of the universal mounting plate and the spigot of the spigot CB wall plate. Slide the hub over the spigot. Make sure the universal mounting plate is at the horizontal and its hub is completely inserted onto the spigot. Normally, the corners of the universal mounting plate hub adapter should touch the catch basin wall.
7. From ground above using a reach bar, lower the ICD device by hooking the end of the reach bar to the handle of the ICD device. Align the triangular plate portion into the mounting wall plate. Push down the device to be sure it has centered into the mounting plate and has created a seal.



**CAUTION/WARNING/DISCLAIM:**

- Verify that the inlet(s) pipe(s) is not protruding into the catch basin. If it is, cut it back so that the inlet pipe is flush with the catch basin wall.
- Any required cement in the installation must be approved for PVC.
- The solvent cement should not be used below 0°C (32°F) or in a high humidity environment. Please refer to the IPEX solvent cement guide to confirm required curing times or attend the IPEX [Online Solvent Cement Training Course](#).
- Call your IPEX representative for more information or if you have any questions about our products.

## **IPEX TEMPEST Inlet Control Devices Technical Specification**

### **General**

Inlet control devices (ICD's) are designed to provide flow control at a specified rate for a given water head level and also provide odour and floatable control where specified. All ICD's will be IPEX Tempest or approved equal.

All devices shall be removable from a universal mounting plate. An operator from street level using only a T-bar with a hook will be able to retrieve the device while leaving the universal mounting plate secured to the catch basin wall face. The removal of the TEMPEST devices listed above must not require any unbolting or special manipulation or any special tools.

High Flow (HF) Sump devices will consist of a removable threaded cap which can be accessible from street level with out entry into the catchbasin (CB). The removal of the threaded cap shall not require any special tools other than the operator's hand.

ICD's must have no moving parts.

### **Materials**

ICD's are to be manufactured from Polyvinyl Chloride (PVC) or Polyurethane material, designed to be durable enough to withstand multiple freeze-thaw cycles and exposure to harsh elements.

The inner ring seal will be manufactured using a Buna or Nitrile material with hardness between Duro 50 and Duro 70.

The wall seal is to be comprised of a 3/8" thick Neoprene Closed Cell Sponge gasket which is attached to the back of the wall plate.

All hardware will be made from 304 stainless steel.

### **Dimensioning**

The Low Medium Flow (LMF), High Flow (HF) and the High Flow (HF) Sump shall allow for a minimum outlet pipe diameter of 200mm with a 600mm deep Catch Basin sump.

### **Installation**

Contractor shall be responsible for securing, supporting and connecting the ICD's to the existing influent pipe and catchbasin/manhole structure as specified and designed by the Engineer.



# THE NEXT GENERATION IN STORM SEWER INLET CONTROLS



STORM WATER FLOW CONTROL



## THE COST-EFFECTIVE SOLUTION TO YOUR STORM WATER SURCHARGE PROBLEMS

- Conserves sewer system capacity
- System accommodates low to high flows
- Integrated odour and floatable control
- Fast and easy to install and maintain



**IPEX**  
by aliaxis

We build tough products for tough environments®





## THE NEXT GENERATION IN STORM SEWER INLET CONTROLS

### ✓ Reduces Sewer Overflows & Basement Backups

Tempest is a family of cost-effective inlet control devices that work together across a series of catch basins to limit the amount of storm water runoff that can enter a combined sewer system during a storm event. Basement backups and sewer overflows are avoided because storm water surcharges are controlled at the sewer inlet and are allowed to remain in catch basins or temporarily above ground.

### ✓ Integrated Odour & Floatable Control

In addition to flow control, Tempest systems can also alleviate sewer system odour emissions as well as prevent floating debris from entering the sewer system.

### ✓ Wide Range of Models & Pre-set Flow Rates

Available in a wide range of patent pending models and pre-set flow rates, Tempest systems can accommodate most storm water flow control requirements from 32 GPM to 270 GPM and beyond. Application specific solutions can also be engineered to meet your unique needs in both wet and dry catch basin environments.

### ✓ Easy to Install & Maintain

Constructed from durable PVC, Tempest units are corrosion free and built to last. The Tempest's light weight design accommodates both square and round catch basins and features a universal back plate and interchangeable components with no moving parts that makes the units quick and easy to install over a catch basin outlet pipe.

These devices also include a quick release mechanism to allow easy access for service without the need to drain the installation.

**Tempest Inlet Control Devices restrict flow to a narrower range than traditional methods regardless of head**

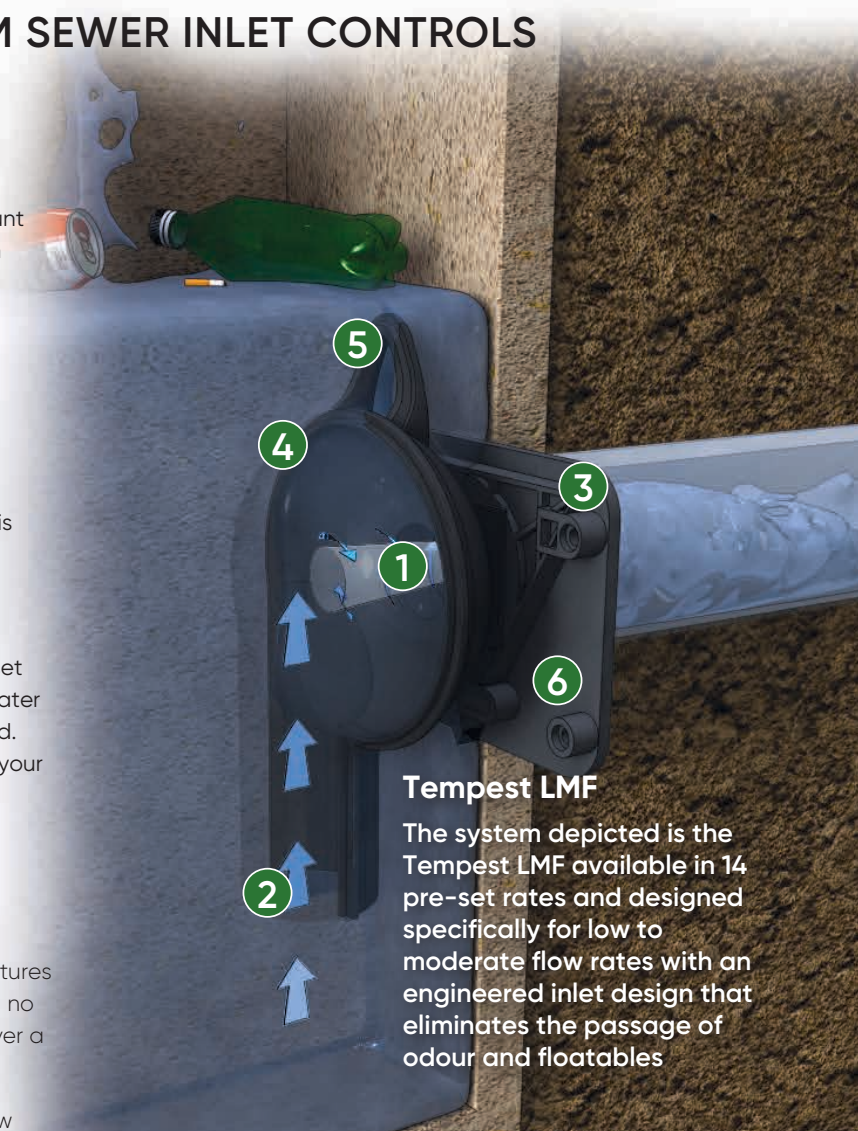
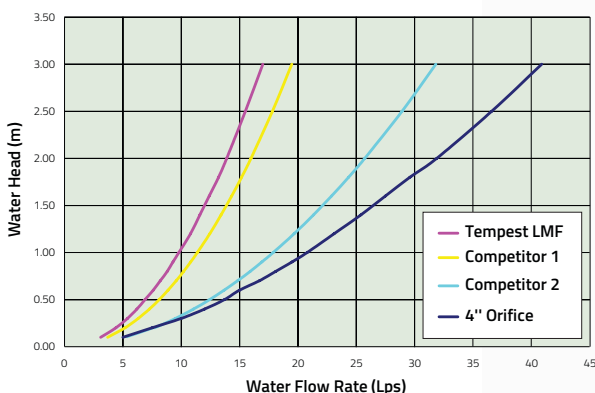

### Tempest LMF

The system depicted is the Tempest LMF available in 14 pre-set rates and designed specifically for low to moderate flow rates with an engineered inlet design that eliminates the passage of odour and floatables

### FEATURES & BENEFITS

- 1 Restricts flow to a narrow range regardless of head
- 2 Unit design prevents the passage of floatables and odours
- 3 Neoprene gasket for air-tight seal\*
- 4 Virtually maintenance free and corrosion free durable PVC construction
- 5 Features a quick release mechanism that's accessed with reach bar. Unit can then be simply lifted out for easy maintenance\*
- 6 Universal back plates available for both square and round catch basins\*

\* Excluding Tempest HF Sump

## THE TEMPEST FAMILY OF SYSTEMS

### TEMPEST LMF



- Restricts:
- ✓ Flow
  - ✓ Odours
  - ✓ Floatables

**LOW to MODERATE FLOW RATES**  
 32 GPM (2 L/s) – 270 GPM (17 L/s)  
 14 pre-set flow rates

The Tempest LMF system features a vortex inlet design that allows a low flow rate to be set and eliminates the passage of odours and floatables and allows for debris and sediment to collect in the structure.

### TEMPEST MHF



- Restricts:
- ✓ Flow

**MEDIUM TO HIGH FLOW RATES**  
 143 GPM (9L/s) or greater  
 Specified pre-set flow rates

The Tempest MHF is a standard orifice plate or plug device designed to allow a specified flow volume through the outlet pipe at a specified head.

### TEMPEST HF & HF SUMP



- Restricts:
- ✓ Flow
  - ✓ Odours
  - ✓ Floatables

**HIGH FLOW RATES**  
 240 GPM (15 L/s) or greater  
 5 pre-set flow rates

The standard Tempest HF system allows a near constant discharge rate to be set and eliminates the passage of odours and floatables and allows for debris and sediment to collect in the structure.

The Tempest HF SUMP system is designed for catch basins & manholes in which there is no sump or the outlet pipe is too low to install standard Tempest device.

### UNIVERSAL BACK PLATES

Available for BOTH square and round catch basins.\*



For square catch basins



For round catch basins

## SOLUTION: TEMPEST INLET CONTROL SYSTEMS



- Provides control by restricting flow into the sewer system
- Provides temporary ponding in catch basins, parking lots & roadways
- Helps preserve sewer capacity, slows down the inlet flow
- Reduces residential flooding and flash flooding
- Water surcharge is controlled and directed as per engineer design
- Can accommodate outlet pipes 6" and larger

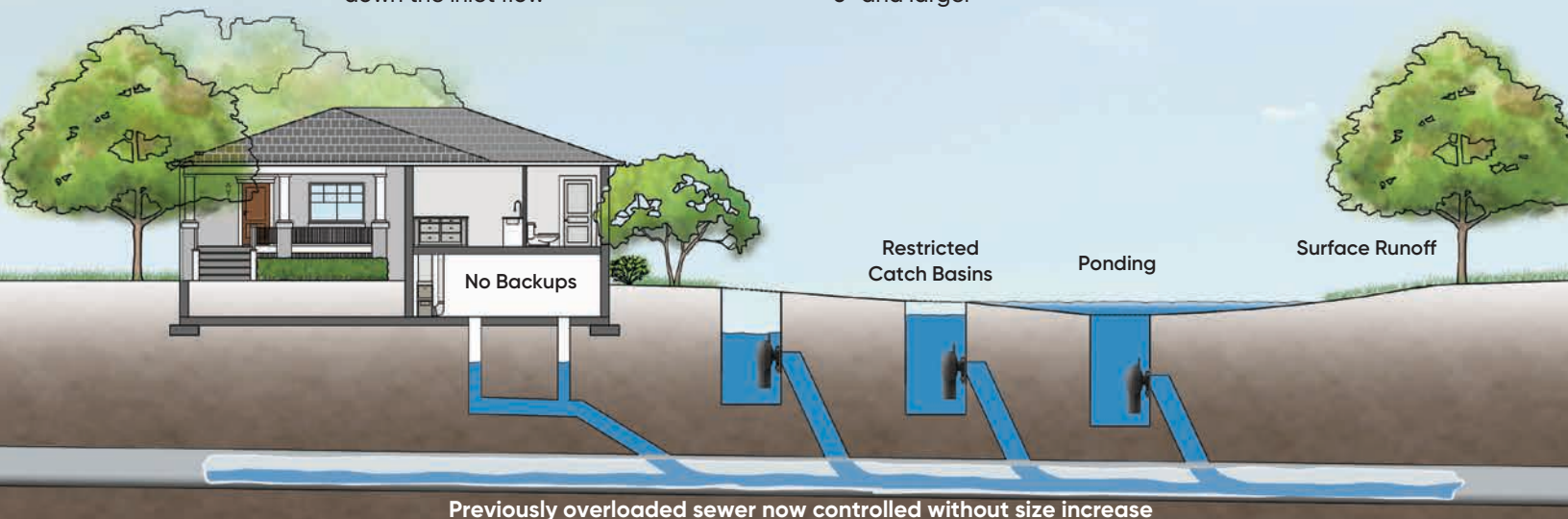

## CUSTOMER SERVICE CENTRE

IPEX Inc.

Toll Free: (866) 473-9462

ipexna.com

### About the IPEX Group of Companies

As leading suppliers of thermoplastic piping systems, the IPEX Group of Companies provides our customers with some of the largest and most comprehensive product lines. All IPEX products are backed by more than 50 years of experience. With state-of-the-art manufacturing facilities and distribution centers across North America, we have earned a reputation for product innovation, quality, end-user focus and performance.

Markets served by IPEX group products are:

- Electrical systems
- Telecommunications and utility piping systems
- PVC, CPVC, PP, PVDF, PE, ABS, and PEX pipe and fittings
- Industrial process piping systems
- Municipal pressure and gravity piping systems
- Plumbing and mechanical piping systems
- Electrofusion systems for gas and water
- Industrial, plumbing and electrical cements
- Irrigation systems

Products manufactured by IPEX Inc.

TEMPEST™ is a trademark of IPEX Branding Inc.

This literature is published in good faith and is believed to be reliable. However, it does not represent and/or warrant in any manner the information and suggestions contained in this brochure. Data presented is the result of laboratory tests and field experience.

A policy of ongoing product improvement is maintained. This may result in modifications of features and/or specifications without notice.



A2 Pre Existing Minor System to Channel	5	1.09	107.0	170	0
A2 Pre Existing Major System to Channel	100	1.09	200.6	398	0
A2 Post Proposed Minor System to Channel	5	0.7	107.0	116	-54
A2 Post Proposed Major System to Channel	100	1.07	200.6	395	-3

### 3.3 Quality and Erosion Control

As the developments and future developments indicated in the Evendale FSR utilize 80% TSS removal the TSS loading from these areas will mimic grass areas which is lower than the 35% imperviousness that was allotted for these areas draining to the Barton SWM Pond (refer to Table 2.1 of the Barton Pond SWM Report). This will offset the small ditch area on Brock Street draining towards the Barton Pond that is being filled and paved. Also, the ditch areas are being filled with sidewalks which are generally clean as they are for pedestrian traffic. As the total flow towards the pond will remain generally the same, it is anticipated that there will not be any significant impacts to erosion control.

Due to the Brock Street Urbanization the passive ditch treatment of stormwater for the road has been reduced to the natural channel. As discussed with the LSRCA and the Region, an OGS unit that is ETV certified has been agreed to be used to satisfy quality control as a result of the loss of the ditches. A Stormceptor OGS unit has been proposed. Refer to the **Servicing Drawing** for the location of the Stormceptor OGS unit and model type. Refer to ETV Certification and OGS to sizing calculations provided in **Appendix B**. As the total flow towards the channel are less than existing conditions as shown in **Section 3.2**, it is anticipated that there will not be any significant impacts to erosion control towards the natural channel.

## 4 Stormsewer Conveyance

To evaluate the storm sewer conveyance system performance, controlled and uncontrolled flows to various sections of the storm sewer network were analyzed.

The following drainage areas were analyzed as 5-year controlled flows draining into the storm sewer network with the following assumptions:

- A5 Post and A15 Post with flows of 3.5 L/s and 7 L/s respectively as per the Evendale FSR were modified to a total pipe target flow from both areas of 11 L/s. **Section 3.1** and calculations in **Appendix B** provide further information on how that target flow was calculated;
- A12 Post with 1505L/s 100-year flow as per the Westlane FSR;
- Due to limited information, A13 Post shown on **Drawing STM-01** was assumed to be controlled such that the effective runoff coefficient would be 0.37. The runoff coefficient of 0.75 from the ST-1 drawing for Coral Creek drainage plan was not used because it is unknown as to how much flow that area was required to control to and flows are required to be estimated for the storm sewer design sheet analysis. The runoff coefficient of 0.37 was determined by reviewing the Barton Pond SWM Report **Catchment Area 105**. According to the report approximately 4.2 ha from **Catchment Area 105** at an imperviousness of 35% (converted to a runoff coefficient of 0.48) was allowed to drain towards the pond from areas that include Brock Street and some areas to

Stormceptor® EF Sizing Report

<b>STORMCEPTOR®</b>		08/06/2020															
<b>ESTIMATED NET ANNUAL SEDIMENT (TSS) LOAD REDUCTION</b>																	
Province:	Ontario	Project Name:	Brock St. E and Herrema Blvd.														
City:	Uxbridge	Project Number:	-														
Nearest Rainfall Station:	TORONTO CENTRAL	Designer Name:	Brandon O'Leary														
NCDC Rainfall Station Id:	0100	Designer Company:	Forterra														
Years of Rainfall Data:	18	Designer Email:	brandon.oleary@forterrabp.com														
Site Name:	Brock St. E and Herrema Blvd.	Designer Phone:	905-630-0359														
Drainage Area (ha):	0.50	EOR Name:	Ken Lo														
Runoff Coefficient 'c':	0.87	EOR Company:	Masongsong Associates Engineering Ltd.														
Particle Size Distribution:	Fine	EOR Email:															
Target TSS Removal (%):	80.0	EOR Phone:															
Required Water Quality Runoff Volume Capture (%):	90.0	<table border="1" style="width: 100%; border-collapse: collapse;"> <thead> <tr> <th colspan="2"><b>Net Annual Sediment (TSS) Load Reduction Sizing Summary</b></th> </tr> <tr> <th>Stormceptor Model</th> <th>TSS Removal Provided (%)</th> </tr> </thead> <tbody> <tr> <td>EFO4</td> <td>83</td> </tr> <tr> <td>EFO6</td> <td>89</td> </tr> <tr> <td>EFO8</td> <td>91</td> </tr> <tr> <td>EFO10</td> <td>92</td> </tr> <tr> <td>EFO12</td> <td>92</td> </tr> </tbody> </table>		<b>Net Annual Sediment (TSS) Load Reduction Sizing Summary</b>		Stormceptor Model	TSS Removal Provided (%)	EFO4	83	EFO6	89	EFO8	91	EFO10	92	EFO12	92
<b>Net Annual Sediment (TSS) Load Reduction Sizing Summary</b>																	
Stormceptor Model	TSS Removal Provided (%)																
EFO4	83																
EFO6	89																
EFO8	91																
EFO10	92																
EFO12	92																
Estimated Water Quality Flow Rate (L/s):	6.83																
Oil / Fuel Spill Risk Site?	Yes																
Upstream Flow Control?	No																
Peak Conveyance (maximum) Flow Rate (L/s):																	
<p><b>Recommended Stormceptor EFO Model: EFO4</b></p> <p><b>Estimated Net Annual Sediment (TSS) Load Reduction (%): 83</b></p> <p><b>Water Quality Runoff Volume Capture (%): &gt; 90</b></p>																	



Stormceptor® **EF** Sizing Report

**THIRD-PARTY TESTING AND VERIFICATION**

► Stormceptor® EF and Stormceptor® EFO are the latest evolutions in the Stormceptor® oil-grit separator (OGS) technology series, and are designed to remove a wide variety of pollutants from stormwater and snowmelt runoff. These technologies have been third-party tested in accordance with the Canadian ETV **Procedure for Laboratory Testing of Oil-Grit Separators** and performance has been third-party verified in accordance with the **ISO 14034 Environmental Technology Verification (ETV)** protocol.

**PERFORMANCE**

► Stormceptor® EF and EFO remove stormwater pollutants through gravity separation and floatation, and feature a patent-pending design that generates positive removal of total suspended solids (TSS) throughout each storm event, including high-intensity storms. Captured pollutants include sediment, free oils, and sediment-bound pollutants such as nutrients, heavy metals, and petroleum hydrocarbons. Stormceptor is sized to remove a high level of TSS from the frequent rainfall events that contribute the vast majority of annual runoff volume and pollutant load. The technology incorporates an internal bypass to convey excessive stormwater flows from high-intensity storms through the device without resuspension and washout (scour) of previously captured pollutants. Proper routine maintenance ensures high pollutant removal performance and protection of downstream waterways.

**PARTICLE SIZE DISTRIBUTION (PSD)**

► The **Canadian ETV PSD** shown in the table below was used, or in part, for this sizing. This is the identical PSD that is referenced in the Canadian ETV **Procedure for Laboratory Testing of Oil-Grit Separators** for both sediment removal testing and scour testing. The Canadian ETV PSD contains a wide range of particle sizes in the sand and silt fractions, and is considered reasonably representative of the particle size fractions found in typical urban stormwater runoff.

Particle Size (µm)	Percent Less Than	Particle Size Fraction (µm)	Percent
1000	100	500-1000	5
500	95	250-500	5
250	90	150-250	15
150	75	100-150	15
100	60	75-100	10
75	50	50-75	5
50	45	20-50	10
20	35	8-20	15
8	20	5-8	10
5	10	2-5	5
2	5	<2	5



Stormceptor® EF Sizing Report

Rainfall Intensity (mm / hr)	Percent Rainfall Volume (%)	Cumulative Rainfall Volume (%)	Flow Rate (L/s)	Flow Rate (L/min)	Surface Loading Rate (L/min/m <sup>2</sup> )	Removal Efficiency (%)	Incremental Removal (%)	Cumulative Removal (%)
1	53.7	53.7	1.21	73.0	60.0	91	48.9	48.9
2	16.9	70.6	2.42	145.0	121.0	85	14.3	63.2
3	8.6	79.2	3.63	218.0	181.0	78	6.7	69.9
4	6.4	85.6	4.84	290.0	242.0	72	4.6	74.5
5	3.1	88.7	6.05	363.0	302.0	67	2.1	76.6
6	2.0	90.7	7.26	435.0	363.0	62	1.2	77.8
7	1.5	92.2	8.47	508.0	423.0	57	0.9	78.7
8	0.7	92.9	9.67	580.0	484.0	56	0.4	79.1
9	1.8	94.7	10.88	653.0	544.0	54	1.0	80.1
10	1.3	96.0	12.09	726.0	605.0	52	0.7	80.7
11	0.9	96.9	13.30	798.0	665.0	52	0.5	81.2
12	0.4	97.3	14.51	871.0	726.0	51	0.2	81.4
13	0.4	97.7	15.72	943.0	786.0	51	0.2	81.6
14	0.4	98.1	16.93	1016.0	847.0	51	0.2	81.8
15	0.2	98.3	18.14	1088.0	907.0	51	0.1	81.9
16	0.0	98.3	19.35	1161.0	967.0	50	0.0	81.9
17	0.0	98.3	20.56	1233.0	1028.0	50	0.0	81.9
18	0.2	98.5	21.77	1306.0	1088.0	49	0.1	82.0
19	0.0	98.5	22.98	1379.0	1149.0	49	0.0	82.0
20	0.0	98.5	24.19	1451.0	1209.0	48	0.0	82.0
21	0.0	98.5	25.40	1524.0	1270.0	47	0.0	82.0
22	0.0	98.5	26.60	1596.0	1330.0	47	0.0	82.0
23	0.0	98.5	27.81	1669.0	1391.0	46	0.0	82.0
24	0.4	98.9	29.02	1741.0	1451.0	44	0.2	82.2
25	0.0	98.9	30.23	1814.0	1512.0	43	0.0	82.2



Stormceptor® EF Sizing Report

Rainfall Intensity (mm / hr)	Percent Rainfall Volume (%)	Cumulative Rainfall Volume (%)	Flow Rate (L/s)	Flow Rate (L/min)	Surface Loading Rate (L/min/m <sup>2</sup> )	Removal Efficiency (%)	Incremental Removal (%)	Cumulative Removal (%)
26	0.2	99.1	31.44	1887.0	1572.0	41	0.1	82.3
27	0.0	99.1	32.65	1959.0	1633.0	40	0.0	82.3
28	0.0	99.1	33.86	2032.0	1693.0	38	0.0	82.3
29	0.2	99.3	35.07	2104.0	1753.0	37	0.1	82.3
30	0.0	99.3	36.28	2177.0	1814.0	36	0.0	82.3
31	0.0	99.3	37.49	2249.0	1874.0	34	0.0	82.3
32	0.2	99.5	38.70	2322.0	1935.0	33	0.1	82.4
33	0.2	99.7	39.91	2394.0	1995.0	32	0.1	82.5
34	0.0	99.7	41.12	2467.0	2056.0	31	0.0	82.5
35	0.0	99.7	42.33	2540.0	2116.0	31	0.0	82.5
36	0.0	99.7	43.53	2612.0	2177.0	30	0.0	82.5
37	0.0	99.7	44.74	2685.0	2237.0	29	0.0	82.5
38	0.0	99.7	45.95	2757.0	2298.0	28	0.0	82.5
39	0.0	99.7	47.16	2830.0	2358.0	27	0.0	82.5
40	0.0	99.7	48.37	2902.0	2419.0	27	0.0	82.5
41	0.0	99.7	49.58	2975.0	2479.0	26	0.0	82.5
42	0.0	99.7	50.79	3047.0	2540.0	25	0.0	82.5
43	0.0	99.7	52.00	3120.0	2600.0	25	0.0	82.5
44	0.0	99.7	53.21	3193.0	2660.0	25	0.0	82.5
45	0.0	99.7	54.42	3265.0	2721.0	25	0.0	82.5
46	0.0	99.7	55.63	3338.0	2781.0	25	0.0	82.5
47	0.2	99.9	56.84	3410.0	2842.0	25	0.1	82.5
48	0.0	99.9	58.05	3483.0	2902.0	25	0.0	82.5
49	0.0	99.9	59.26	3555.0	2963.0	25	0.0	82.5
50	0.0	99.9	60.47	3628.0	3023.0	25	0.0	82.5
<b>Estimated Net Annual Sediment (TSS) Load Reduction =</b>								<b>83 %</b>





Stormceptor® EF Sizing Report

RAINFALL DATA FROM TORONTO CENTRAL RAINFALL STATION

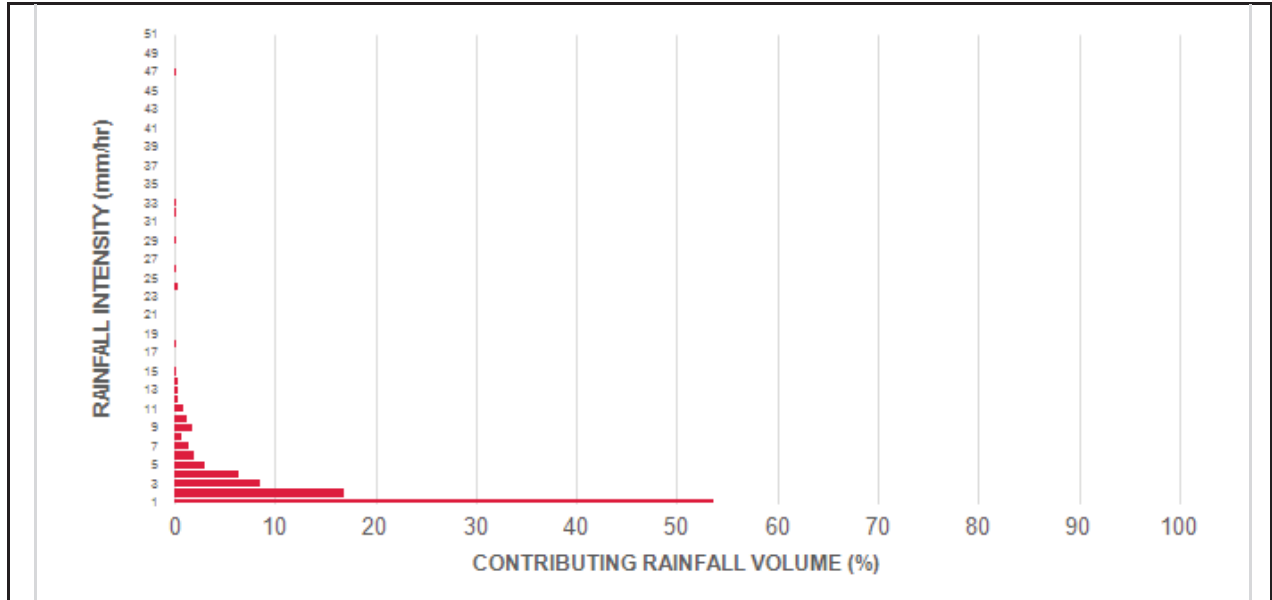

INCREMENTAL AND CUMULATIVE TSS REMOVAL FOR THE RECOMMENDED STORMCEPTOR® MODEL

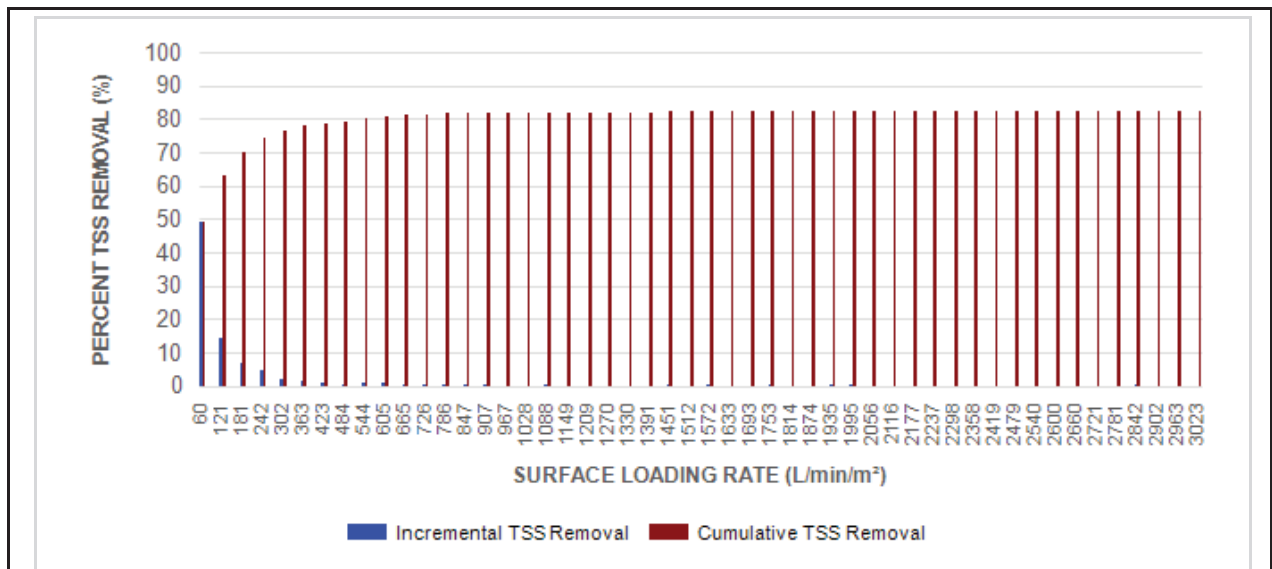

Stormceptor® EF Sizing Report

Maximum Pipe Diameter / Peak Conveyance

Stormceptor EF / EFO	Model Diameter		Min Angle Inlet / Outlet Pipes	Max Inlet Pipe Diameter		Max Outlet Pipe Diameter		Peak Conveyance Flow Rate	
	(m)	(ft)		(mm)	(in)	(mm)	(in)	(L/s)	(cfs)
EF4 / EFO4	1.2	4	90	609	24	609	24	425	15
EF6 / EFO6	1.8	6	90	914	36	914	36	990	35
EF8 / EFO8	2.4	8	90	1219	48	1219	48	1700	60
EF10 / EFO10	3.0	10	90	1828	72	1828	72	2830	100
EF12 / EFO12	3.6	12	90	1828	72	1828	72	2830	100

**SCOUR PREVENTION AND ONLINE CONFIGURATION**

► Stormceptor® EF and EFO feature an internal bypass and superior scour prevention technology that have been demonstrated in third-party testing according to the scour testing provisions of the Canadian ETV Procedure for Laboratory Testing of Oil-Grit Separators, and the exceptional scour test performance has been third-party verified in accordance with the ISO 14034 ETV protocol. As a result, Stormceptor EF and EFO are approved for online installation, eliminating the need for costly additional bypass structures, piping, and installation expense.

**DESIGN FLEXIBILITY**

► Stormceptor® EF and EFO offers design flexibility in one simplified platform, accepting stormwater flow from a single inlet pipe or multiple inlet pipes, and/or surface runoff through an inlet grate. The device can also serve as a junction structure, accommodate a 90-degree inlet-to-outlet bend angle, and can be modified to ensure performance in submerged conditions.

**OIL CAPTURE AND RETENTION**

► While Stormceptor® EF will capture and retain oil from dry weather spills and low intensity runoff, Stormceptor® EFO has demonstrated superior oil capture and greater than 99% oil retention in third-party testing according to the light liquid re-entrainment testing provisions of the Canadian ETV Procedure for Laboratory Testing of Oil-Grit Separators. Stormceptor EFO is recommended for sites where oil capture and retention is a requirement.



Stormceptor® EF Sizing Report

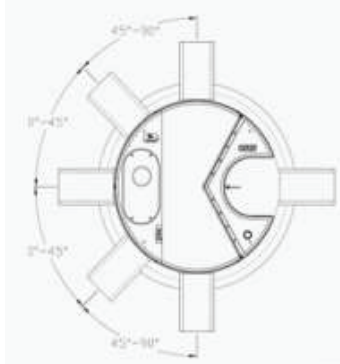

**INLET-TO-OUTLET DROP**

Elevation differential between inlet and outlet pipe inverts is dictated by the angle at which the inlet pipe(s) enters the unit.

0° - 45° : The inlet pipe is 1-inch (25mm) higher than the outlet pipe.

45° - 90° : The inlet pipe is 2-inches (50mm) higher than the outlet pipe.

**HEAD LOSS**

The head loss through Stormceptor EF is similar to that of a 60-degree bend structure. The applicable K value for calculating minor losses through the unit is 1.1. For submerged conditions the applicable K value is 3.0.

**Pollutant Capacity**

Stormceptor EF / EFO	Model Diameter		Depth (Outlet Pipe Invert to Sump Floor)		Oil Volume		Recommended Sediment Maintenance Depth *		Maximum Sediment Volume *		Maximum Sediment Mass **	
	(m)	(ft)	(m)	(ft)	(L)	(Gal)	(mm)	(in)	(L)	(ft³)	(kg)	(lb)
EF4 / EFO4	1.2	4	1.52	5.0	265	70	203	8	1190	42	1904	5250
EF6 / EFO6	1.8	6	1.93	6.3	610	160	305	12	3470	123	5552	15375
EF8 / EFO8	2.4	8	2.59	8.5	1070	280	610	24	8780	310	14048	38750
EF10 / EFO10	3.0	10	3.25	10.7	1670	440	610	24	17790	628	28464	78500
EF12 / EFO12	3.6	12	3.89	12.8	2475	655	610	24	31220	1103	49952	137875

\*Increased sump depth may be added to increase sediment storage capacity

\*\* Average density of wet packed sediment in sump = 1.6 kg/L (100 lb/ft³ )

Feature	Benefit	Feature Appeals To
Patent-pending enhanced flow treatment and scour prevention technology	Superior, verified third-party performance	Regulator, Specifying & Design Engineer
Third-party verified light liquid capture and retention for EFO version	Proven performance for fuel/oil hotspot locations	Regulator, Specifying & Design Engineer, Site Owner
Functions as bend, junction or inlet structure	Design flexibility	Specifying & Design Engineer
Minimal drop between inlet and outlet	Site installation ease	Contractor
Large diameter outlet riser for inspection and maintenance	Easy maintenance access from grade	Maintenance Contractor & Site Owner

**STANDARD STORMCEPTOR EF/EFO DRAWINGS**

For standard details, please visit <http://www.imbriumsystems.com/stormwater-treatment-solutions/stormceptor-ef>

**STANDARD STORMCEPTOR EF/EFO SPECIFICATION**

For specifications, please visit <http://www.imbriumsystems.com/stormwater-treatment-solutions/stormceptor-ef>



## STANDARD PERFORMANCE SPECIFICATION FOR “OIL GRIT SEPARATOR” (OGS) STORMWATER QUALITY TREATMENT DEVICE

### PART 1 – GENERAL

#### 1.1 WORK INCLUDED

This section specifies requirements for selecting, sizing, and designing an underground Oil Grit Separator (OGS) device for stormwater quality treatment, with third-party testing results and a Statement of Verification in accordance with ISO 14034 Environmental Management – Environmental Technology Verification (ETV).

#### 1.2 REFERENCE STANDARDS & PROCEDURES

ISO 14034:2016 Environmental management – Environmental technology verification (ETV)

Canadian Environmental Technology Verification (ETV) Program’s **Procedure for Laboratory Testing of Oil-Grit Separators**

#### 1.3 SUBMITTALS

1.3.1 All submittals, including sizing reports & shop drawings, shall be submitted upon request with each order to the contractor then forwarded to the Engineer of Record for review and acceptance. Shop drawings shall detail all OGS components, elevations, and sequence of construction.

1.3.2 Alternative devices shall have features identical to or greater than the specified device, including: treatment chamber diameter, treatment chamber wet volume, sediment storage volume, and oil storage volume.

1.3.3 Unless directed otherwise by the Engineer of Record, OGS stormwater quality treatment product substitutions or alternatives submitted within ten days prior to project bid shall not be accepted. All alternatives or substitutions submitted shall be signed and sealed by a local registered Professional Engineer, based on the exact same criteria detailed in Section 3, in entirety, subject to review and approval by the Engineer of Record.

### PART 2 – PRODUCTS

#### 2.1 OGS POLLUTANT STORAGE

The OGS device shall include a sump for sediment storage, and a protected volume for the capture and storage of petroleum hydrocarbons and buoyant gross pollutants. The minimum sediment & petroleum hydrocarbon storage capacity shall be as follows:

2.1.1	4 ft (1219 mm) Diameter OGS Units:	1.19 m <sup>3</sup> sediment / 265 L oil
	6 ft (1829 mm) Diameter OGS Units:	3.48 m <sup>3</sup> sediment / 609 L oil
	8 ft (2438 mm) Diameter OGS Units:	8.78 m <sup>3</sup> sediment / 1,071 L oil
	10 ft (3048 mm) Diameter OGS Units:	17.78 m <sup>3</sup> sediment / 1,673 L oil
	12 ft (3657 mm) Diameter OGS Units:	31.23 m <sup>3</sup> sediment / 2,476 L oil

## PART 3 – PERFORMANCE & DESIGN

### 3.1 GENERAL

The OGS stormwater quality treatment device shall be verified in accordance with ISO 14034:2016 Environmental management – Environmental technology verification (ETV). The OGS stormwater quality treatment device shall remove oil, sediment and gross pollutants from stormwater runoff during frequent wet weather events, and retain these pollutants during less frequent high flow wet weather events below the insert within the OGS for later removal during maintenance. The Manufacturer shall have at least ten (10) years of local experience, history and success in engineering design, manufacturing and production and supply of OGS stormwater quality treatment device systems, acceptable to the Engineer of Record.

### 3.2 SIZING METHODOLOGY

The OGS device shall be engineered, designed and sized to provide stormwater quality treatment based on treating a minimum of 90 percent of the average annual runoff volume and a minimum removal of an annual average 60% of the sediment (TSS) load based on the Particle Size Distribution (PSD) specified in the sizing report for the specified device. Sizing shall be determined using historical rainfall data and a sediment removal performance curve derived from the actual third-party verified laboratory testing data. The OGS device shall also have sufficient annual sediment storage capacity as specified and calculated in Section 2.1.

### 3.3 CANADIAN ETV or ISO 14034 ETV VERIFICATION OF SCOUR TESTING

The OGS device shall have Canadian ETV or ISO 14034 ETV Verification of third-party scour testing conducted in accordance with the Canadian ETV Program's **Procedure for Laboratory Testing of Oil-Grit Separators**.

3.3.1 To be acceptable for on-line installation, the OGS device must demonstrate an average scour test effluent concentration less than 10 mg/L at each surface loading rate tested, up to and including 2600 L/min/m<sup>2</sup>.

### 3.4 LIGHT LIQUID RE-ENTRAINMENT SIMULATION TESTING

The OGS device shall have Canadian ETV or ISO 14034 ETV Verification of completed third-party Light Liquid Re-entrainment Simulation Testing in accordance with the Canadian ETV **Program's Procedure for Laboratory Testing of Oil-Grit Separators**, with results reported within the Canadian ETV or ISO 14034 ETV verification. This re-entrainment testing is conducted with the device pre-loaded with low density polyethylene (LDPE) plastic beads as a surrogate for light liquids such as oil and fuel. Testing is conducted on the same OGS unit tested for sediment removal to assess whether light liquids captured after a spill are effectively retained at high flow rates.

3.4.1 For an OGS device to be an acceptable stormwater treatment device on a site where vehicular traffic occurs and the potential for an oil or fuel spill exists, the OGS device must have reported verified performance results of greater than 99% cumulative retention of LDPE plastic beads for the five specified surface loading rates (ranging 200 L/min/m<sup>2</sup> to 2600 L/min/m<sup>2</sup>) in accordance with the Light Liquid Re-entrainment Simulation Testing within the Canadian ETV Program's **Procedure for Laboratory Testing of Oil-Grit Separators**. However, an OGS device shall not be allowed if the Light Liquid Re-entrainment Simulation Testing was performed with screening components within the OGS device that are effective at retaining the LDPE plastic beads, but would not be expected to retain light liquids such as oil and fuel.

# STANDARD PERFORMANCE SPECIFICATION FOR “OIL GRIT SEPARATOR” (OGS) STORMWATER QUALITY TREATMENT DEVICE

## PART 1 – GENERAL

### 1.1 WORK INCLUDED

This section specifies requirements for selecting, sizing, and designing an underground Oil Grit Separator (OGS) device for stormwater quality treatment, with third-party testing results and a Statement of Verification in accordance with ISO 14034 Environmental Management – Environmental Technology Verification (ETV).

### 1.2 REFERENCE STANDARDS & PROCEDURES

ISO 14034:2016 Environmental management – Environmental technology verification (ETV)

Canadian Environmental Technology Verification (ETV) Program’s **Procedure for Laboratory Testing of Oil-Grit Separators**

### 1.3 SUBMITTALS

1.3.1 All submittals, including sizing reports & shop drawings, shall be submitted upon request with each order to the contractor then forwarded to the Engineer of Record for review and acceptance. Shop drawings shall detail all OGS components, elevations, and sequence of construction.

1.3.2 Alternative devices shall have features identical to or greater than the specified device, including: treatment chamber diameter, treatment chamber wet volume, sediment storage volume, and oil storage volume.

1.3.3 Unless directed otherwise by the Engineer of Record, OGS stormwater quality treatment product substitutions or alternatives submitted within ten days prior to project bid shall not be accepted. All alternatives or substitutions submitted shall be signed and sealed by a local registered Professional Engineer, based on the exact same criteria detailed in Section 3, in entirety, subject to review and approval by the Engineer of Record.

## PART 2 – PRODUCTS

### 2.1 OGS POLLUTANT STORAGE

The OGS device shall include a sump for sediment storage, and a protected volume for the capture and storage of petroleum hydrocarbons and buoyant gross pollutants. The **minimum** sediment & petroleum hydrocarbon storage capacity shall be as follows:

2.1.1	4ft (1219mm) Diameter OGS Units:	1.19m <sup>3</sup> sediment / 265L oil
	6ft (1829mm) Diameter OGS Units:	3.48m <sup>3</sup> sediment / 609L oil
	8ft (2438mm) Diameter OGS Units:	8.78m <sup>3</sup> sediment / 1,071L oil
	10ft (3048mm) Diameter OGS Units:	17.78m <sup>3</sup> sediment / 1,673L oil
	12ft (3657mm) Diameter OGS Units:	31.23m <sup>3</sup> sediment / 2,476L oil

## PART 3 – PERFORMANCE & DESIGN

### 3.1 GENERAL

The OGS stormwater quality treatment device shall be verified in accordance with ISO 14034:2016 Environmental management – Environmental technology verification (ETV). The OGS stormwater quality

treatment device shall remove oil, sediment and gross pollutants from stormwater runoff during frequent wet weather events, and retain these pollutants during less frequent high flow wet weather events below the insert within the OGS for later removal during maintenance. The Manufacturer shall have at least ten (10) years of local experience, history and success in engineering design, manufacturing and production and supply of OGS stormwater quality treatment device systems, acceptable to the Engineer of Record.

### 3.2 SIZING METHODOLOGY

The OGS device shall be engineered, designed and sized to provide stormwater quality treatment based on treating a minimum of 90 percent of the average annual runoff volume and a minimum removal of an annual average 60% of the sediment (TSS) load based on the Particle Size Distribution (PSD) specified in the sizing report for the specified device. Sizing shall be determined using historical rainfall data and a sediment removal performance curve derived from the actual third-party verified laboratory testing data. The OGS device shall also have sufficient annual sediment storage capacity as specified and calculated in Section 2.1.

### 3.3 CANADIAN ETV or ISO 14034 ETV VERIFICATION OF SCOUR TESTING

The OGS device shall have Canadian ETV or ISO 14034 ETV Verification of third-party scour testing conducted in accordance with the Canadian ETV Program's **Procedure for Laboratory Testing of Oil-Grit Separators**.

3.3.1 To be acceptable for on-line installation, the OGS device must demonstrate an average scour test effluent concentration less than 10 mg/L at each surface loading rate tested, up to and including 2600 L/min/m<sup>2</sup>.

### 3.4 LIGHT LIQUID RE-ENTRAINMENT SIMULATION TESTING

The OGS device shall have Canadian ETV or ISO 14034 ETV Verification of completed third-party Light Liquid Re-entrainment Simulation Testing in accordance with the Canadian ETV Program's **Procedure for Laboratory Testing of Oil-Grit Separators**, with results reported within the Canadian ETV or ISO 14034 ETV verification. This re-entrainment testing is conducted with the device pre-loaded with low density polyethylene (LDPE) plastic beads as a surrogate for light liquids such as oil and fuel. Testing is conducted on the same OGS unit tested for sediment removal to assess whether light liquids captured after a spill are effectively retained at high flow rates.

3.4.1 For an OGS device to be an acceptable stormwater treatment device on a site where vehicular traffic occurs and the potential for an oil or fuel spill exists, the OGS device must have reported verified performance results of greater than 99% cumulative retention of LDPE plastic beads for the five specified surface loading rates (ranging 200 L/min/m<sup>2</sup> to 2600 L/min/m<sup>2</sup>) in accordance with the Light Liquid Re-entrainment Simulation Testing within the Canadian ETV Program's **Procedure for Laboratory Testing of Oil-Grit Separators**. However, an OGS device shall not be allowed if the Light Liquid Re-entrainment Simulation Testing was performed with screening components within the OGS device that are effective at retaining the LDPE plastic beads, but would not be expected to retain light liquids such as oil and fuel.





## **APPENDIX D**

### **- Hydrogeological Assessment Water Balance Study**



EVENDALE DEVELOPMENTS LTD.

# HYDROGEOLOGICAL ASSESSMENT AND WATER BALANCE STUDY

## BLOCK 8 - PART OF LOT 31, CONCESSION 7, UXBRIDGE

NOVEMBER 17, 2020

DRAFT







# HYDROGEOLOGICAL ASSESSMENT AND WATER BALANCE STUDY

BLOCK 8 - PART OF LOT 31,  
CONCESSION 7, UXBRIDGE

EVENDALE DEVELOPMENTS LTD.

DRAFT

PROJECT NO.: 181-00471-02

DATE: NOVEMBER 17, 2020

WSP  
UNIT 2  
126 DON HILLOCK DRIVE  
AURORA, ON, CANADA L4G 0G9

T: +1 905 750-3080

F: +1 905 727-0463

WSP.COM





November 17, 2020

DRAFT

EVENDALE DEVELOPMENTS LTD.  
2 Farr Avenue  
Sharon, Ontario  
L0G 1V0

**Attention: Mr. David Sud**

Dear David:

**Subject: Hydrogeological Assessment and Water Balance Study  
Block 8, Part of Lot 31, Concession 7, Uxbridge**

WSP Canada Inc. (WSP) is pleased to submit the attached report to document the Hydrogeological Assessment and Water Balance Study prepared for a proposed residential development on Block 8 within Part of Lot 31, Concession 7, Uxbridge, Ontario (Site).

The report provides an assessment of the existing hydrogeological conditions beneath the Site as well as water budgets for existing and future conditions to illustrate the likely changes in water balance that would be expected due to the proposed development. The report includes a preliminary assessment of anticipated dewatering requirements for the proposed residential condominium based on observed conditions.

We trust that this information is sufficient for your current needs. If you have any questions or require further information, please contact us.

Yours truly,

DRAFT

Lloyd Lemon, P.Geo., M.Sc.  
Senior Project Geoscientist

VLB/LALdlw

WSP ref.: 181-00471-02

H:\Proj\18\181-00471-00\100 Hydrogeological\Wp\Report\181-00471-02 Hydrogeological Assessment and Water Balance Study (Block 8) 2020-11-17\_Draft.docx

UNIT 2  
126 DON HILLOCK DRIVE  
AURORA, ON, CANADA L4G 0G9

T: +1 905 750-3080  
F: +1 905 727-0463  
wsp.com





---

# EXECUTIVE SUMMARY

WSP Canada Inc. (WSP) was retained by Evendale Developments Ltd. to prepare a Hydrogeological Assessment and Water Balance Study for the proposed residential development on Block 8 of Part of Lot 31, Concession 7, in the Township of Uxbridge (Site). The development plans for Block 8 include the streets, six (6) detached residential homes, and a six (6)-storey residential condominium building including one (1) level underground parking garage.

The proposed development area lies within the Peterborough Drumlin Field physiographic region as defined by Chapman and Putnam (1984). The Peterborough Drumlin Field is typically characterized by deposits of highly calcareous till, but the local area surrounding the Site is mapped as clay plains.

The on-site runoff generally drains to the northwest via overland flow, towards the proposed Lowe Blvd extension and is captured in the drainage ditch along Donland Lane.

Based on previous geotechnical investigations conducted at the Site the proposed development area is underlain by a shallow layer of topsoil which is followed by a heterogenous mixture layer of fill or probable fill ranging in texture from gravel, sand, silt and clay to a thickness of 2.3 to 3.1 m. The Fill overlies a layer of clayey silt to silty clay on the east side of the property and overlies layers of silty sand on the west side of the Site. This pattern is consistent with the surficial geology mapping presented on a regional scale and with stratigraphy information presented in water well records obtained through the MECP. The information presented in the Sola borehole logs from review of physical samples does not confirm that the clayey silt to silty clay formation will typically overlie the silty sand formation but this is implied from regional stratigraphic understanding.

Seasonal high groundwater levels were observed in April 2020 in BH2 (268.61 masl) and BH5 (267.81 masl), and in January 2018 in MW1 (268.10 masl) and in MW2 (268.05 masl). The measured seasonally high groundwater levels correspond to depths of 1.59 mbgs at BH2, 1.49 mbgs at BH5, 0.13 mbgs at MW1 and 1.12 mbgs at MW2. The lowest groundwater levels were observed in October 2020 at BH2 (267.71 masl), in August 2020 at BH5 (267.76 masl), in July 2018 at MW1 (267.09 masl) and at MW2 (267.41 masl). Typically, groundwater levels are observed to be the highest between February and May and also in the late fall, while groundwater levels tend to be lowest between July and October. The observed groundwater levels generally follow the typical groundwater level trends.

The hydraulic conductivity estimates obtained from the on-site monitoring wells for the single well hydraulic response tests were  $9.84 \times 10^{-8}$  m/sec,  $6.20 \times 10^{-6}$  m/sec and  $4.01 \times 10^{-7}$  m/sec for BH2, BH5 and MW1, respectively. These results are consistent with the observed soil descriptions of the clayey silty at BH2, fill (sand) at BH5 and silty sand at MW1 in which the monitoring wells are screened. The hydraulic conductivity estimate obtained from the off-site monitoring wells for the single well hydraulic response tests was  $4.90 \times 10^{-7}$  for MW2. This result is consistent with the observed soil descriptions of the silty sand at MW2 in which the monitoring wells are screened.

Two (2) groundwater samples were collected from the existing monitoring wells on February 14th, 2017. The concentrations of the parameters tested were less than the values of the MECP Table 2: Full Depth Generic Site Condition Standards in a Potable Ground Water Condition for All Types of Property Use (Coarse Textured Soil).

The Climate-Based Water Budget indicates that average annual precipitation over the past 30 years is 886.2 mm/year. The available moisture surplus at the Site ranges between 321.8 mm/yr to 336.8 mm/year depending on the type of soil and vegetation cover. The moisture surplus will reflect the infiltration and runoff based on the soil properties, slopes, and vegetation within individual catchments.

Under existing conditions, there is one (1) on-site catchment. Runoff generated on-site drains to the northwest via overland flow and is captured in the drainage ditch along Donland Lane. Runoff subsequently flows south along Donland Lane and exits the Site through the southern property boundary.

The Pre-Development Water Budget reflects infiltration for the Site of approximately 2,216 m<sup>3</sup>/yr and runoff from the Site of approximately 3,256 m<sup>3</sup>/yr.

The Post-Development Water Budget reflects changes in land use to include increased areas of impervious surfaces (i.e. roads, buildings etc.) and re-grading. The proposed development area has been subdivided into four (4) on-site catchments. The majority of the runoff generated under post development conditions will be directed off-site to the Barton SWM Pond located approximately 500 m to the north of the Site via storm sewers.

The Post-Development Water Budget predicts a total on-site infiltration of 818 m<sup>3</sup>/yr. Overall, this is a decrease of 63% relative to the Pre-Development case, and represents an infiltration deficit of 1,399 m<sup>3</sup>/yr.

The Post-Development Water Budget predicts a net runoff of 7,837 m<sup>3</sup>/yr over the Site area. This is an increase of 141% or 4,581 m<sup>3</sup>/yr relative to the Pre-Development case. The runoff generated from the impervious surfaces in the post-development scenario has entirely been captured by the onsite catch basin and is redirected from the south property boundary to the Barton SWM Pond.

The estimated pumping rate that may be experienced to maintain dry conditions during construction is up to 176,600 L/day. WSP recommends that the dewatering activity be registered on the EASR prior to construction. Additional groundwater quality testing is recommended to confirm suitability for discharge to nearby Region of Durham storm sewers.

The majority of the proposed footing elevations are below the seasonally high water table. Estimates of the dewatering rates to maintain dry foundations are up to 85,500 L/day, including a 2X factor of safety. Water proofing of the basement/underground parking is recommended to reduce the potential that water is being removed and to thereby comply with Policy DEMD-1.

The Site lies within WHPA-Q1 and WHPA-Q2 for the Uxbridge Water Supply system with assigned stress levels of moderate. Source Protection Plan (SPP) policies for WHPA-Q1 apply to areas where activities that take water without returning it to the same source may be a threat. SPP policies for WHPA-Q2 apply to areas where activities that reduce recharge might be a threat. Based on the estimated volumes of water that may require removal during construction and long-term drainage of the residential condominium, the Site will need to comply further with policies for WHPA-Q1. As per the South Georgian Bay Lake Simcoe Protection Region, Approved Source Protection Plan, policy number DEMD-1 will apply to the water taking activities during dewatering for construction and long-term drainage. Policies associated with WHPA – Q2 may apply to offset identified infiltration deficit relative to pre-development conditions.

The proposed development area is mapped within a Highly Vulnerable Aquifer (HVA) area with a vulnerability score of 6. The Site will be municipally serviced for sewage which will eliminate potential contamination of groundwater by nitrates and phosphorous. De-icing agents applied on impervious surfaces such as driveways and roadways will be collected by the on-site storm sewer system and released to the Barton SWM Pond. This will help to minimize the amount of de-icing agents that infiltrate into the groundwater. Best management practices will likely require that the use of salt for winter road de-icing be minimized.

The proposed development is located within a Significant Groundwater Recharge Area with a vulnerability score of 6.

The Site lies within Intake Protection Zone 3 (IPZ-3) for Lake Simcoe. The majority of the runoff directed to Lake Simcoe leaves the Site to north after detention in the Barton stormwater management pond and is not likely to contain contaminants of concern. The potential for release of contaminants to surface water that will reach Lake Simcoe from the Site is minimal given the proposed residential land use. Winter road de-icing agents could potentially cause runoff contamination as the residence will include driveway and roadway areas. Mixing with clean runoff will reduce the concentration of these chemicals to an acceptable level prior to reaching Lake Simcoe and therefore the proposed activity does not present a water quality threat to the municipal surface water sources protected by the Source Protection Plan.

---

# SIGNATURES

## PREPARED BY

DRAFT

---

Valyn Bernard, P.Eng.  
Project Engineer

## REVIEWED BY

DRAFT

---

Lloyd Lemon, P.Ge., M.Sc.  
Senior Project Geoscientist

WSP CANADA INC (“WSP”) prepared this report solely for the use of the intended recipient, EVENDALE DEVELOPMENTS LTD., in accordance with the professional services agreement between the parties. In the event a contract has not been executed, the parties agree that the WSP General Terms for Consultant shall govern their business relationship which was provided to you prior to the preparation of this report.

The report is intended to be used in its entirety. No excerpts may be taken to be representative of the findings in the assessment.

The conclusions presented in this report are based on work performed by trained, professional and technical staff, in accordance with their reasonable interpretation of current and accepted engineering and scientific practices at the time the work was performed.

The content and opinions contained in the present report are based on the observations and/or information available to WSP at the time of preparation, using investigation techniques and engineering analysis methods consistent with those ordinarily exercised by WSP and other engineering/scientific practitioners working under similar conditions, and subject to the same time, financial and physical constraints applicable to this project.

WSP disclaims any obligation to update this report if, after the date of this report, any conditions appear to differ significantly from those presented in this report; however, WSP reserves the right to amend or supplement this report based on additional information, documentation or evidence.

WSP makes no other representations whatsoever concerning the legal significance of its findings.

The intended recipient is solely responsible for the disclosure of any information contained in this report. If a third party makes use of, relies on, or makes decisions in accordance with this report, said third party is solely responsible for such use, reliance or decisions. WSP does not accept responsibility for damages, if any, suffered by any third party as a result of decisions made or actions taken by said third party based on this report.

WSP has provided services to the intended recipient in accordance with the professional services agreement between the parties and in a manner consistent with that degree of care, skill and diligence normally provided by members of the same profession performing the same or comparable services in respect of projects of a similar nature in similar

circumstances. It is understood and agreed by WSP and the recipient of this report that WSP provides no warranty, express or implied, of any kind. Without limiting the generality of the foregoing, it is agreed and understood by WSP and the recipient of this report that WSP makes no representation or warranty whatsoever as to the sufficiency of its scope of work for the purpose sought by the recipient of this report.

In preparing this report, WSP has relied in good faith on information provided by others, as noted in the report. WSP has reasonably assumed that the information provided is correct and WSP is not responsible for the accuracy or completeness of such information.

Benchmark and elevations used in this report are primarily to establish relative elevation differences between the specific testing and/or sampling locations and should not be used for other purposes, such as grading, excavating, construction, planning, development, etc.

Design recommendations given in this report are applicable only to the project and areas as described in the text and then only if constructed in accordance with the details stated in this report. The comments made in this report on potential construction issues and possible methods are intended only for the guidance of the designer. The number of testing and/or sampling locations may not be sufficient to determine all the factors that may affect construction methods and costs. We accept no responsibility for any decisions made or actions taken as a result of this report unless we are specifically advised of and participate in such action, in which case our responsibility will be as agreed to at that time.

Overall conditions can only be extrapolated to an undefined limited area around these testing and sampling locations. The conditions that WSP interprets to exist between testing and sampling points may differ from those that actually exist. The accuracy of any extrapolation and interpretation beyond the sampling locations will depend on natural conditions, the history of Site development and changes through construction and other activities. In addition, analysis has been carried out for the identified chemical and physical parameters only, and it should not be inferred that other chemical species or physical conditions are not present. WSP cannot warrant against undiscovered environmental liabilities or adverse impacts off-Site.

The original of this digital file will be kept by WSP for a period of not less than 10 years. As the digital file transmitted to the intended recipient is no longer under the control of WSP, its integrity cannot be assured. As such, WSP does not guarantee any modifications made to this digital file subsequent to its transmission to the intended recipient.

This limitations statement is considered an integral part of this report.



# TABLE OF CONTENTS

1	INTRODUCTION.....	1
1.1	Objectives and Scope .....	1
1.2	Analysis and Documentation .....	2
2	REGIONAL SETTING .....	2
2.1	Physiography.....	2
2.2	Drainage .....	2
2.3	Regional Geology .....	2
2.4	Regional Hydrogeology .....	3
2.4.1	Regional Groundwater Movement.....	4
3	WORK PERFORMED .....	5
3.1	Background Review of Geological Conditions .....	5
3.2	Previous Geotechnical Investigations .....	5
3.3	Site Reconnaissance and Groundwater Elevation Measurements .....	5
3.4	Single-Well Hydraulic Response Test.....	6
3.5	Water Quality .....	6
3.6	Water Budget Analysis .....	7
3.6.1	Analysis of Climate Data.....	7
3.6.2	Pre-Development Water Budget .....	8
3.6.3	Post-Development Water Budget With Mitigation .....	9
4	OBSERVATIONS.....	9
4.1	Soil Profile.....	9
4.2	Groundwater Elevations .....	9
4.3	Water Use .....	10
4.3.1	MECP Water Well Search .....	10
4.4	Single-Well Hydraulic Response Tests.....	10
4.5	Water Quality Testing .....	11



<b>5</b>	<b>WATER BUDGET ANALYSIS .....</b>	<b>11</b>
<b>5.1</b>	<b>Climate-Based Water Budget .....</b>	<b>11</b>
<b>5.2</b>	<b>Pre-Development Water Budget .....</b>	<b>12</b>
5.2.1	Pre-Development Catchments .....	12
5.2.2	Pre-Development Analysis .....	12
5.2.3	Pre-Development Infiltration .....	12
5.2.4	Pre-Development Runoff .....	13
<b>5.3</b>	<b>Water Budget– Post-Development Conditions .....</b>	<b>13</b>
5.3.1	Post-Development Catchments.....	13
5.3.2	Post-Development Analysis.....	13
5.3.3	Post-Development Infiltration .....	14
5.3.4	Post-Development Runoff.....	14
5.3.5	Comparison with Pre-Development .....	14
<b>5.4</b>	<b>Water Quality .....</b>	<b>14</b>
5.4.1	Existing Conditions.....	14
5.4.2	Future Conditions .....	15
<b>6</b>	<b>DEWATERING ASSESSMENT.....</b>	<b>15</b>
<b>6.1</b>	<b>Dewatering Equations and Assumptions .....</b>	<b>15</b>
<b>6.2</b>	<b>Assumptions.....</b>	<b>16</b>
<b>6.3</b>	<b>Construction Dewatering Calculations .....</b>	<b>17</b>
<b>6.4</b>	<b>Long-Term Drainage .....</b>	<b>18</b>
<b>6.5</b>	<b>Dewatering Summary.....</b>	<b>18</b>
<b>7</b>	<b>POLICY AREAS .....</b>	<b>19</b>
<b>7.1</b>	<b>Wellhead Protection Areas.....</b>	<b>19</b>
<b>7.2</b>	<b>Highly Vulnerable Aquifers .....</b>	<b>19</b>
<b>7.3</b>	<b>Significant Groundwater Recharge Areas .....</b>	<b>20</b>
<b>7.4</b>	<b>Intake Protection Zones.....</b>	<b>20</b>



8	CONCLUSIONS.....	20
9	REFERENCES.....	23

---

## *TABLES*

TABLE 1	OBSERVED GROUNDWATER ELEVATIONS
TABLE 2	SINGLE WELL RESPONSE TEST RESULTS
TABLE 3	WATER QUALITY RESULTS
TABLE 4	CLIMATE BASED WATER BUDGET SUMMARY
TABLE 5	WATER BALANCE SUMMARY
TABLE 6	DEWATERING ESTIMATES SUMMARY

---

## *FIGURES*

FIGURE 1	SITE LOCATION MAP
FIGURE 2	EXISTING CONDITIONS
FIGURE 3	REGIONAL PHYSIOGRAPHY
FIGURE 4	REGIONAL TOPOGRAPHY AND DRAINAGE
FIGURE 5	REGIONAL SURFICIAL GEOLOGY
FIGURE 6	REGIONAL BEDROCK GEOLOGY
FIGURE 7	OVERBURDEN THICKNESS
FIGURE 8	MECP WATER WELLS
FIGURE 9	GROUNDWATER ELEVATIONS – APRIL 2020
FIGURE 10	PRE-DEVELOPMENT SITE CATCHMENT AREAS
FIGURE 11	POST-DEVELOPMENT SITE CATCHMENT AREAS
FIGURE 12	PROPOSED BASEMENT LEVEL FOOTING ELEVATIONS
FIGURE 13	CROSS SECTION A-A'
FIGURE 14	WELLHEAD PROTECTION AREAS
FIGURE 15	HIGH VULNERABLE AQUIFERS
FIGURE 16	SIGNIFICANT GROUNDWATER RECHARGE AREAS
FIGURE 17	INTAKE PROTECTION ZONES



---

## *APPENDICES*

- A PROPOSED SITE PLANS
- B MECP WATER WELL RECORDS AND GEOTECHNICAL BOREHOLE LOGS
- C IN-SITU HYDRAULIC CONDUCTIVITY TESTING
- D WATER QUALITY TESTING
- E CLIMATE BASED WATER BUDGET
- F WATER BUDGET CALCULATIONS – PRE-DEVELOPMENT
- G WATER BUDGET CALCULATIONS – POST DEVELOPMENT
- H DEWATERING CALCULATIONS

# 1 INTRODUCTION

WSP Canada Inc. (WSP) was retained by Evendale Developments Ltd. to prepare a Hydrogeological Assessment and Water Balance Study for a proposed residential development on Block 8 of Part of Lot 31, Concession 7 in the Town of Uxbridge, herein referred to as the Site. The location of the Site is shown on **Figure 1**.

The Site (development Block 8) is approximately 0.5 ha in size and is located northeast of the intersection of Brock Street East and Donland Lane in the Town of Uxbridge, Ontario. The existing conditions at the Site are shown in **Figure 2**. The Site is currently occupied by agricultural fields in the northern half of the Site and a gravel parking lot in the southern half of the Site. The development plans provided by Masongsong Associates Engineering Limited are included in **Appendix A** and encompasses six detached residential homes and a six (6)-storey residential condominium building including one (1) level underground parking garage.

Previous reports made available for review for preparing the Hydrogeological Assessment and Water Balance Study included:

- Geotechnical Investigation Report, Sola Engineering Inc (Sola), April 2020.
- Hydrogeological Assessment and Water Balance Study, Block 6 – Part of Lot 31, Concession 7, Uxbridge, July 30, 2020.
- Hydrogeological Assessment and Water Balance Study, Part of Lot 31, Concession 7, Uxbridge, March 28, 2018.

The geotechnical characterization of the Site provided by Sola has been used to assist in identifying appropriate infiltration factors for soil types. The monitoring wells installed by Sola have been used to characterize local groundwater conditions.

This report documents the work performed to provide an understanding of the hydrogeological conditions at the Site, to prepare a water balance, to identify dewatering requirements (if applicable), and provide preliminary estimates of dewatering based on the proposed building conditions.

---

## 1.1 OBJECTIVES AND SCOPE

The need for a water balance assessment and infiltration study was identified to help support the development application process and quantify changes to site infiltration between the pre- and post-development conditions for the development plan.

The Hydrogeological Assessment and Water Balance Study has been designed to:

- Review historical information and integrate findings.
- Identify the inventory of groundwater users within 500 m of the property.
- Confirm groundwater flow directions and patterns.
- Confirm and identify potential watershed divides, if any, which control groundwater flow.
- Characterize the water quality of the shallow groundwater.
- Characterize the relationships between on-site groundwater flow systems and adjacent surface water bodies.
- Create an annual water budget for the existing conditions at the property for use as a baseline.
- Determine a future annual water budget for the proposed development scenario.
- Identify significant changes to the water balance or to the form and function of the groundwater or surface water systems that might result from future plans and provide recommendations for mitigative measures to address these changes.
- Identify potential impacts of dewatering for construction and long-term drainage of foundation drains.
- Prepare a project report.

---

## 1.2 ANALYSIS AND DOCUMENTATION

The following published information and mapping was reviewed and considered in our analysis of the Site:

- Hydrogeological Assessments - Conservation Authority Guidelines to Support Development Applications, April 2013.
- Assessment Report, South Georgian Bay Lake Simcoe Source Protection Region, Part 1 (Lake Simcoe, May 2015 update). Approved Lakes Simcoe and Couchiching Source Protection Plan.
- Lake Simcoe Protection Plan, Water Budget Offsetting Policy for LSPP 4.8-DP and 6.40 DP.
- Ministry of Environment, Conservation and Parks Water Well Information System (MECP WWIS);
- Other sources of information as listed in **Section 8.0**.

## 2 REGIONAL SETTING

---

### 2.1 PHYSIOGRAPHY

The regional physiography for the Site area is shown on **Figure 3**. The proposed development area lies within the Peterborough Drumlin Field physiographic region as defined by Chapman and Putnam (1984). The Peterborough Drumlin Field consists of highly calcareous till but there are local differences. The area in and surrounding the Site consists of clay plains.

Regional topography is illustrated on **Figure 4**. The topography is variable and hummocky and controls local drainage. Topography at the Site ranges from elevation 268.6 m at the north-west property boundary to 271.17 at the south-east property boundary. Topography to the east and south of the site increases gently toward the watershed divides between the Lake Simcoe watershed and the Kawartha-Haliburton Watershed and the Humber-Don River Watershed, respectively.

---

### 2.2 DRAINAGE

The Site is located approximately 3 km east of the divide between the Lake Simcoe Watershed and the Kawartha-Haliburton Watershed, and approximately 9.5 km north of the drainage divide between the Lake Simcoe Watershed and the Don-Humber River Watershed. The watershed boundaries are illustrated on **Figure 4**.

The on-site runoff generally drains to the northwest via overland flow, towards the proposed Lowe Blvd extension and is captured in the drainage ditch along Donland Lane.

---

### 2.3 REGIONAL GEOLOGY

The near surface soils are the top unit in a layered sequence of glacial and interglacial sediments that comprise the stratigraphic profile overlying bedrock beneath the Lake Simcoe region. The distribution of surficial soil types near the site are shown on **Figure 5**. The deposits and stratigraphy are described in a series of papers and posters for the regional area prepared by the Geological Survey of Canada under the direction of Dr. David Sharpe.

The stratigraphic profile beneath Oak Ridges Moraine area typically includes the following layers, from youngest to oldest:

- 1 Recent deposits.
- 2 Oak Ridges Moraine (ORM) Sediments
- 3 Newmarket Till.

- 4 Thorncliffe Formation.
- 5 Sunnybrook Drift.
- 6 Scarborough Formation.
- 7 Don Formation.
- 8 York Till.
- 9 Bedrock.

The ORM sediments are a complex package of granular sediments deposited in the meltwater at the later stages of the last glacial period. These deposits generally become finer, and typically become thinner and eventually pinch out away from the original outlets of meltwater. These sediments may be present as a thin layer based on the proximity of the Site to the Oak Ridges Moraine as per regional geological mapping. Certain areas with the ORM sediments may be overlain by a thin layer of Halton Till.

The Newmarket Till represents a regionally extensive stratum that is associated with the most recent period of glaciation. This till is typically dense to very hard and sandy to silty in texture with relatively low gravel content.

The stratigraphic layers between the Newmarket Till and the underlying bedrock are commonly grouped as the Lower Sediments. The Lower Sediments are considered to have been formed by similar cycles of earlier glacial advances and retreats and associated meltwater events that resulted in the deposition of the Newmarket Till and Oak Ridges Moraine sediments. Five (5) stratigraphic layers that constitute the Lower Sediments are described below, although not all are interpreted to occur below the study area.

- The Thorncliffe Formation is a complex of stratified glaciofluvial and glaciolacustrine deposits. The texture of the Thorncliffe Formation is highly variable and is best described as fine-grained, with interbedded coarse-grained material capable of yielding notable amounts of water.
- The Sunnybrook Drift is a fine-grained material deposited in glacial and proglacial lacustrine depositional environments (diamicton). The advance of the ice sheet blocked the main drainage from the regional basin, which caused water levels to rise and form a deep lacustrine environment with deposits including varved clays.
- The Scarborough Formation is a coarsening upward sequence of sediment that ranges from clay/silt rhythmites (fine-grained) to channelized cross-bedded sands (coarse-grained). The coarser fractions of this delta are a potential source of groundwater.
- The Don Formation is only rarely preserved within southern Ontario and consists of alternating beds of fossiliferous sand and mud.
- The York Till was deposited immediately overlying the bedrock by the preceding Illinoian glaciation. This till occurs only sporadically within the study area and is believed to be preserved in lows upon the bedrock surface. The till is dark grey with a sandy silt matrix and includes clusters of the underlying shale.

The bedrock in the study area is mapped as shale/limestone/dolostone/siltstone of the Blue Mountain Formation (Armstrong and Dodge, 2007) as illustrated on **Figure 6**. The depth to bedrock is estimated to be between 80 to 85 metres below ground surface, based on bedrock topography mapping and topographic mapping of the ground surface (Gao et al., 2006). A map of overburden thickness is provided on **Figure 7**. The thickness of overburden is typically greatest along the crest of the Oak Ridges Moraine or in areas where there are topographic lows in the underlying bedrock surface.

---

## 2.4 REGIONAL HYDROGEOLOGY

The movement of groundwater through the subsurface is controlled by the hydraulic gradients and the relative distribution of coarse and fine-grained sediments. In general, water will move laterally through coarse-grained sediments (sands and gravels) and vertically through fine-grained sediments (silts and clays). As such, the geologic units are typically grouped into hydrostratigraphic units that reflect the capacity of the geologic units to transmit water. Hydrostratigraphic units are considered to be either aquifers (with good capacity to transmit water) or aquitards (which typically impede transmission of water). Ultimately the distribution and interconnection of aquifers and aquitards are responsible for observed groundwater movement.

Earthfx Inc. (2006) grouped the regional stratigraphic profile into a seven layer hydrostratigraphic profile as follows:

- 1 Recent Deposits
- 2 Oak Ridges Aquifer Complex (ORAC).
- 3 Newmarket Aquitard.
- 4 Thorncliffe Aquifer Complex.
- 5 Sunnybrook Aquitard.
- 6 Scarborough Aquifer Complex.
- 7 Bedrock.

The Oak Ridges Aquifer Complex is a regional aquifer system in Ontario that corresponds to the area where the Oak Ridges Sediments are deposited. The aquifer is a significant source of groundwater for domestic, commercial, industrial, institutional, agricultural, and municipal water supplies. The ORAC provides baseflow to the headwaters of creeks and rivers where the Halton Aquitard is absent. The shallow water table will typically be observed within this layer. The ORAC is present at the Site.

The Newmarket Aquitard consists of the Newmarket Till and low permeability deposits that are known to infill the erosional channels. The Newmarket Aquitard is considered to be a leaky confining layer that provides protection from contamination to aquifers within the underlying hydrostratigraphic units. The Newmarket Aquitard may be present at ground surface beneath the southern part of the Site.

The Thorncliffe Aquifer Complex consists of fine to coarse-grained sediments of the Thorncliffe Formation. Local sand and gravel deposits within the Thorncliffe Aquifer Complex provide high yield wells. Groundwater in this layer is typically under pressure and in areas to the south of Aurora, the groundwater is under artesian pressure which can result in flowing wells.

The Sunnybrook Aquitard separates the Thorncliffe and Scarborough Aquifer Complexes. This aquitard demonstrates low permeability, provides some resistance to vertical groundwater movement, and protects the underlying aquifer from potential contaminant movement.

The Scarborough Aquifer Complex consists of fine to coarse-grained sediments associated with the Scarborough Formation. In general, these sediments tend to be coarse-grained and thicker where they fill topographic lows and valleys in the underlying bedrock surface. Groundwater within the Scarborough Aquifer Complex is typically under pressure, but only local artesian conditions occur. Locally, the Scarborough Aquifer Complex produces high well yields suitable for municipal or commercial wells. Due to its depth and presence of shallower aquifers, the Scarborough Aquifer Complex is not exploited extensively for private water supplies.

---

### 2.4.1 REGIONAL GROUNDWATER MOVEMENT

In general terms, precipitation infiltrates vertically into the surficial clay and sand/gravel soil units. Groundwater will primarily move downward to the water table within the upper aquifer or aquitard unit. Groundwater will then tend to flow up or down through the aquitard units and laterally within the aquifers. Groundwater flow patterns can be influenced by established watercourses where there is potential for groundwater discharge to supply baseflow into the watercourses. The rate of groundwater discharge is controlled by the relative permeability of the recent deposits at the base of the streams. Discharge as baseflow is typically low through fine-grained base soils and higher where the streams have eroded down into coarser aquifers.

The horizontal groundwater movement through the subsurface aquifers tends to reflect the ground surface topography and the presence of stream channels.

# 3 WORK PERFORMED

The work program for the Hydrogeological Assessment and Water Balance Study included the following activities:

- 1 Coordinating field work.
- 2 Undertaking field reconnaissance to inventory site conditions. Site features were located using a calibrated, hand held Global Positioning System (GPS) device with sub-metre accuracy;
- 3 Measuring groundwater elevations at the monitoring wells;
- 4 Conducting in-situ hydraulic response tests on the two (2) on-site monitoring wells to characterize the hydraulic conductivity in the fill and native soil layers.
- 5 Conducting six (6) monthly site visits (October, November, January, March, April, May) to collect groundwater levels from the on-site monitoring wells. The first monitoring event was conducted in conjunction with the in-situ hydraulic response testing. Pressure transducers were installed in both monitoring wells to supplement the manual water level measurements.
- 6 Analyzing field data from the field investigation, Sola Geotechnical Investigation and the Hydrogeological Assessment and Water Balance Study prepared by WSP for the entire development;
- 7 Preparing an annual climatic water budget and Site-specific water balance for Pre- and Post-Development conditions;
- 8 Documenting applicable policy areas and provide opinions on the effect of these policies on the proposed Development; and
- 9 Identifying dewatering requirements (if applicable), and providing preliminary estimates of dewatering volumes based on the proposed building conditions;
- 10 Providing conclusions and recommendations.

---

## 3.1 BACKGROUND REVIEW OF GEOLOGICAL CONDITIONS

The geologic conditions beneath the proposed development were reviewed using published map sources, records from work on adjacent properties, and the WWIS database as maintained by the MECF.

Water well records within a 500-metre radius of the Site were reviewed to obtain information on existing wells and to provide information on the geology of the area. A summary of the well record search is provided in Table B-1, **Appendix B** and water well record locations are plotted on **Figure 8**.

---

## 3.2 PREVIOUS GEOTECHNICAL INVESTIGATIONS

Sola was retained by Evendale Developments Limited to carry out geotechnical investigations for the proposed residential condominium building located in the southern half of the Block 8 development. The investigations consisted of drilling six (6) boreholes to a maximum depth of 10.67 m, with monitoring wells installed in two (2) of the boreholes. The locations of the borehole and monitoring well locations are shown on **Figure 2** and a copy of the borehole logs are included in **Appendix B**.

---

## 3.3 SITE RECONAISSANCE AND GROUNDWATER ELEVATION MEASUREMENTS

WSP staff visited the Site on August 19 and October 21, 2020 and five monthly site visits (November, January, March, April and May, 2021) are planned to measure static groundwater elevations at the two (2) existing monitoring well onsite (BH2 and BH5). The purpose of the groundwater level monitoring program is to characterize seasonal changes to groundwater elevations and determine the high seasonal water level.

A pressure transducer/datalogger and a corresponding Barologger was installed at BH2 and BH5 on October 21, 2020 to automatically record groundwater levels on a regular basis. The groundwater monitoring program will continue after this submission, with regular manual measurements and continued recording of groundwater elevation change using a datalogger for up until May 2021. WSP shall prepare a technical memorandum to summarize the groundwater elevation data obtained at the end of this monitoring period.

---

### 3.4 SINGLE-WELL HYDRAULIC RESPONSE TEST

Single well hydraulic response tests were performed to estimate the hydraulic conductivity of the aquifer materials adjacent to the well screens in BH2 and BH5.

For this program, the single well hydraulic response test consisted of monitoring the recovery of the water level after a short pumping/bailing interval. The recovery data obtained from these response tests was adequate to estimate the *in situ* hydraulic conductivity of the saturated intervals adjacent to the monitoring well screen.

The hydraulic conductivity was estimated from the data using the methods of Hvorslev (1957).

The hydraulic response tests for the on-site wells were performed on October 21, 2020. The results of the Single Well Response Test Analysis are summarized in **Table 2**. Detailed results are provided in **Appendix C**.

Additional single well response tests were completed by WSP on January 25, 2018 at MW1 and MW2, located at the neighbouring development block 6 east of the Site. The hydraulic conductivities estimated from the data obtained in January 2018 were analyzed as part of the hydrogeological assessment, and are discussed in detail in **Section 4.5**.

---

### 3.5 WATER QUALITY

Representative samples of groundwater were collected on February 14, 2017 from MW1 and MW2, located at the neighbouring development block 6 east of the Site. A duplicate sample was taken at MW2 for QA/QC purposes. Samples were collected via the dedicated Waterra™ inertial pump placed in the monitoring well. Field measurements of temperature, electrical conductivity, and pH were recorded at the time of sample collection. The water samples were collected in sample bottles prepared by and provided by ALS Environmental Laboratories (ALS) located in Waterloo, Ontario.

The water quality samples were submitted to determine concentrations of:

- General water quality parameters (major cations, major anions, pH)
- Dissolved Metals
- Dissolved Organic Carbon
- Nutrients.

The Certificates of Analysis provided by ALS are provided in **Appendix D**.

The water quality results were reviewed with respect to Table 2: Full Depth Generic Site Condition Standards in a Potable Ground Water Condition for All Types of Property Use (Coarse Textured Soil), hereinto referred to as the “MECP Table 2 SCS”, as outlined in the Soil, Ground Water and Sediment Standards for Use Under Part XV.1 of the Environmental Protection Act (April 15, 2011). This table was selected as it provides a conservative assessment of potential water quality concerns in groundwater as the area surrounding the Site is serviced by municipal water supplies.

---

## 3.6 WATER BUDGET ANALYSIS

A Water Budget provides an accounting of the water inputs and water outputs within a defined area. In this case, the area of the proposed development is used to estimate the water budgets in the existing condition (Pre-Development) and in the future condition (Post-Development).

The basic assumption of a water budget analysis is that there is a balance between water inputs and outputs, unless there is a clear understanding that water is being removed from storage within the system. The water budget is typically represented in a simple form as:

$$\text{Water In} = \text{Water Out}$$
$$P + EI = ET + IR + RO + EO$$

Where:

P	=	Precipitation
EI	=	External Inputs (including run-on, irrigation, and vertical/lateral transfers)
ET	=	Evapotranspiration
IR	=	Infiltration Recharge
RO	=	Runoff
EO	=	External Outputs (including water taking, and vertical/lateral transfers)

In more complex scenarios, lateral inputs through groundwater and surface water, movement between subsurface aquifer layers, and removal from storage can also be considered.

The objectives of the Water Budget Analysis are to:

- quantify the water budget equation for the existing conditions;
- quantify the water budget equation for proposed future conditions; and
- illustrate that there is either no significant change (i.e. a water balance) between the existing or future conditions, or that mitigation methods can be employed to minimize the estimated change.

The Water Budget Analysis was completed in three main steps:

- Step 1) Analysis of Climatic Data;
- Step 2) Pre-Development Water Budget; and
- Step 3) Post-Development Water Budget (including mitigation).

The water budget analysis has been completed using methods outlined in “Hydrogeological Technical Information Requirements for Land Development Applications” (MOEE, 1995).

---

### 3.6.1 ANALYSIS OF CLIMATE DATA

Climate data available from on-line resources maintained by the Meteorological Service of Canada (Environmental Canada) were obtained and analyzed to determine the appropriate values for annual average precipitation and evapotranspiration. The surplus left over after subtraction of the evapotranspiration from the average precipitation is considered to represent the quantity of water available for infiltration and runoff under existing conditions.

Climate data was obtained for the Udora Climate Station for the period from 1981 until 2010. These data are provided in Table E-1 (**Appendix E**). Mean monthly temperatures were calculated by averaging mean monthly minimum and maximum temperatures. Temperature data were derived from the 30 year (1981-2010) climate data summaries.

The Thornthwaite-Mather method was used to estimate potential and actual evapotranspiration on a monthly basis. The Thornthwaite-Mather method is based on an empirical relationship between potential evapotranspiration and



mean air temperature. The method also takes into account the water holding capacity for the soil to compute the actual evapotranspiration and the resulting moisture surplus that is available for infiltration and runoff.

The water holding capacity of the soil depends on two different factors – the soil type and structure, and the type of vegetation growing on the surface. Different types of soil hold different amounts of moisture storage capacity, while different species of vegetation will send roots into the soil to different depths and therefore retain varying amounts of moisture. The water holding capacity for each soil type/vegetation type combination found on the Site was determined from the Environmental Design Criteria of the Storm Water Management Planning and Design Manual published by the MECP in 2003.

The monthly estimates were used to calculate an annual average for precipitation, potential evapotranspiration, actual evapotranspiration, and available moisture surplus for each combination of soil and vegetation type found on-site. The moisture surplus represents the quantity of water available for infiltration and runoff on an annual average basis. Tables that document the details of the Thornthwaite-Mather analysis for the combinations of soil type and land use are provided in **Appendix E**.

---

### 3.6.2 PRE-DEVELOPMENT WATER BUDGET

The Pre-Development Water Budget was estimated using the approach recommended in Table 2 of the “Hydrogeological Technical Information Requirements for Land Development Applications” (MOEE, 1995). The steps taken to estimate the Pre-Development Water Budget included:

- 1 Identify sensitive features and to observe existing topography, soil types, and other controls on infiltration and runoff.
- 2 Delineating drainage catchments and sub-catchments based on observed drainage outlets and physical characteristics as described below.
- 3 Estimating the quantities of infiltration and runoff for each of the sub-catchment areas and preparing summary estimates for catchments related to identified drainage outlets and for the proposed development area.

The drainage catchments and sub-catchments were defined by considering the following factors:

- Existing elevations;
- Existing property boundaries;
- Post-development features and property boundaries;
- Natural topographical features;
- Slope ratio; and
- Land cover, and
- Land use.

The sub-catchments defined for the Pre-Development Water Budget also considered the proposed development areas and future drainage considerations for the proposed development. This was incorporated into the analysis to be able to demonstrate changes in drainage to the identified outlets and infiltration beneath the development area. The defined sub-catchments for the Pre-Development Water Budget are shown on **Figure 9** and in Table F-1 (**Appendix F**).

The Infiltration Factor for each Pre-Development sub-catchment was estimated by adding the sub-factors for topography, soil type, and land cover as recommended in the MECP methodology. A geographic information system (GIS) was used to evaluate the topography, soil type and land use for each of the Pre-Development, Current Condition, and Post-Development scenarios and to generate a set of sub-catchments that can be used in analysis of each scenario. Section 5 provides a characterization of the Site in terms of the topography, soil type, and land use as input into the water budget analysis. The calculated infiltration factor for each catchment was reviewed and updated manually, as a confirmation that they reflect actual conditions. Assumptions applied to the Pre-Development water budget scenario are described in Section 5.2.

The volume of Pre-Development Infiltration was estimated as the product of [sub-catchment area] x [moisture surplus] x [Infiltration factor]. The Pre-Development Runoff was estimated by subtracting the volume of infiltration

from the total volume of moisture surplus for each sub-catchment. A detailed table to document the calculations of the Pre-development Water Budget is provided in **Appendix F**.

---

### 3.6.3 POST-DEVELOPMENT WATER BUDGET

The Post-Development Water Budget was estimated using a similar approach as outlined for the Pre-Development case. The proposed development plan and future drainage plan were used to establish new drainage sub-catchments that relate to the outlets identified in the Pre-Development case. Within each drainage sub-catchment, the area of pervious soils and impervious development (roads, driveways, amenities, and roofs) were estimated based on the Site and grading plans as provided by Cole Engineering.

For the pervious areas, the quantity of infiltration was calculated using the [pervious area] x [precipitation surplus] x [Infiltration Factor]. The Infiltration Factors were reviewed to correspond to the Post-Development conditions. The runoff for the pervious areas was estimated by subtracting the volume of infiltration from the total volume of precipitation surplus for the pervious area in each sub-catchment.

The volume of runoff from the impervious surfaces was estimated using the area of impervious surfaces and the volume of precipitation. A factor of 10% was considered to represent some evaporation in the course of runoff. This value is consistent with assumptions made on adjacent lands.

The proposed residential development is to be serviced by municipal water and sewage system. The Post-Development Water Budget reflects this.

Details of the Post-Development Water Budget calculations are provided in **Appendix G**.

## 4 OBSERVATIONS

The information obtained during previous site studies was reviewed and analyzed to characterize the soil profile and the groundwater system at the Site.

---

### 4.1 SOIL PROFILE

According to previous geotechnical investigations conducted at the Site by Sola (April, 2020), the proposed development area is underlain by a shallow layer of topsoil which is followed by a layer heterogenous mixture of fill or probable fill ranging in texture from gravel, sand, silt and clay to a thickness of 2.3 to 3.1 m. The Fill overlies a layer of clayey silt to silty clay on the east side of the property and overlies layers of silty sand on the west side of the Site. This pattern is consistent with the surficial geology mapping presented on a regional scale in **Figure 5** and with stratigraphy information presented in water well records obtained through the MECPC. The information presented in the Sola borehole logs from review of physical samples does not confirm that the clayey silt to silty clay formation will typically overlie the silty sand formation but this is implied from regional stratigraphic understanding.

---

### 4.2 GROUNDWATER ELEVATIONS

As noted in the Sola geotechnical report (2020), the groundwater elevations at the two (2) on-site monitoring well (BH2 and BH5) were measured in April 2020. Additional groundwater elevations were measured by WSP at the on-site monitoring wells installed by Sola in August and October 2020. As part of the groundwater elevation monitoring program for the entire property, the groundwater elevations at one on-site monitoring well (MW1) and one off-site monitoring well (MW2) were measured in January, February and April 2018 and were measured again on a monthly basis for a period of one (1) year. Additional groundwater elevations were measured from monitoring well MW1 in May 2020, and from monitoring well MW2 in May, August and October 2020. MW1 was not available after May 2020. The groundwater elevation measurements are summarized in **Table 1**.

The measured groundwater depths and elevations at the on-site monitoring wells indicate that groundwater levels were observed to vary between 1.59 and 2.49 mbgs at BH2 and 1.49 and 1.55 mbgs at BH5 between April and October 2020. The observed groundwater level ranges correspond to groundwater elevation ranges of 267.71 to 268.61 m above sea level (masl) for monitoring well BH2 and 267.76 masl to 267.81 masl for monitoring well BH5.

The groundwater elevations in the monitoring well at BH5 reflect the water levels within the fill formation on the west side of the Site. The groundwater elevations at BH2 reflect the water levels within the clayey silt to silty clay on the central and east side of the proposed site of the condo structure.

The measured groundwater depths and elevations at MW1 and MW2 indicate that groundwater levels were observed to vary between 0.34 and 1.14 mbgs at MW1 and 1.12 and 1.76 mbgs at MW2 throughout 2018 and the beginning of 2019. The observed groundwater level ranges correspond to groundwater elevation ranges of 267.09 to 267.89 m above sea level (masl) for monitoring well MW1 and 267.41 masl to 268.05 masl for monitoring well MW2.

Seasonal high groundwater levels were observed in April 2020 in BH2 (268.61 masl) and BH5 (267.81 masl), and in January 2018 in MW1 (268.10 masl) and in MW2 (268.05 masl). The measured seasonally high groundwater levels correspond to depths of 1.59 mbgs at BH2, 1.49 mbgs at BH5, 0.13 mbgs at MW1 and 1.12 mbgs at MW2. The lowest groundwater levels were observed in October 2020 at BH2 (267.71 masl), in August 2020 at BH5 (267.76 masl), in July 2018 at MW1 (267.09 masl) and at MW2 (267.41 masl). Typically, groundwater levels are observed to be the highest between February and May and also in the late fall, while groundwater levels tend to be lowest between July and October. The observed groundwater levels generally follow the typical groundwater level trends.

The seasonally high groundwater elevations measured to date from available monitors and the interpreted groundwater flow direction are presented on **Figure 9**. The apparent groundwater flow direction is inferred to be in the northerly direction. This inferred groundwater direction is generally consistent with topography at the Site and regional groundwater flow patterns, which indicates a gradual slope from south to north.

---

## 4.3 WATER USE

The Site is not currently serviced as it is a vacant lot. The proposed development will be municipally serviced for water and sewage.

---

### 4.3.1 MECP WATER WELL SEARCH

A list of MECP water well records is provided in **Appendix B**. **Figure 8** illustrates the locations of wells located within 500 m of the Site as per the MECP WWIS. The well record database includes seventy-seven (77) water well records within a 500-metre radius of the Site. Of the well records, ten (10) are water supply wells for domestic, irrigation and livestock purposes, twenty-two (22) are test holes, seventeen (17) are abandoned for other purposes, twelve (12) are monitoring wells, fourteen (14) are unknown, one (1) is a dewatering well, one (1) is for other purposes.

Of the ten (10) water supply wells, four (4) draw water from sand lenses at a depth less than 20 m and six (6) draw water from sand lenses at depths ranging between 20 and 40 m. It is our understanding that this area is municipally serviced for water and that most of the domestic water supply wells have been removed from active use as this area has been developed.

It is possible that the MECP WWIS database includes other wells that are incorrectly located and there may be some wells for which well records are not on file at the MECP.

---

## 4.4 SINGLE-WELL HYDRAULIC RESPONSE TESTS

A single well hydraulic response test was performed to estimate the hydraulic conductivity of the aquifer materials adjacent to the well screens in BH2, BH5, MW1 and MW2.

For this program, the single well hydraulic response test consisted of monitoring the recovery of the water level after a short pumping/bailing interval. The recovery data obtained from these response tests was adequate to estimate the *in situ* hydraulic conductivity of the saturated intervals adjacent to the monitoring well screen.

The hydraulic conductivity was estimated from the data using the methods of Hvorslev (1957).

The hydraulic response tests for MW1 and MW2 were performed on February 1, 2018, and tests for BH2 and BH5 were performed on October 21 and 22, 2020. The results of the Single Well Response Test Analysis are summarized in **Table 2**. Detailed results are provided in **Appendix C**.

The hydraulic conductivity estimates obtained from the on-site monitoring wells for the single well hydraulic response tests were  $9.84 \times 10^{-8}$  m/sec,  $6.20 \times 10^{-6}$  m/sec and  $4.01 \times 10^{-7}$  m/sec for BH2, BH5 and MW1, respectively. These results are consistent with the observed soil descriptions of the clayey silty at BH2, fill (sand) at BH5 and silty sand at MW1 in which the monitoring wells are screened.

The hydraulic conductivity estimate obtained from the off-site monitoring wells for the single well hydraulic response tests was  $4.90 \times 10^{-7}$  m/sec for MW2. This result is consistent with the observed soil descriptions of the silty sand at MW2 in which the monitoring wells are screened.

---

## 4.5 WATER QUALITY TESTING

The results of water quality testing at the one on-site (MW1) and one off-site (MW2) monitoring wells are summarized in **Table 3**. The water quality analysis reports as provided by ALS are presented in **Appendix D**.

The concentrations of the parameters tested are less than the MECP Table 2 SCS values. Additional groundwater quality testing will be required to determine potential discharge options during construction dewatering activities.

# 5 WATER BUDGET ANALYSIS

The Water Budget Analysis is presented in the following sections. Section 5.1 describes the analysis of historical climate data to estimate annual average precipitation and potential evapotranspiration. Section 5.2 describes the Pre-Development Water Budget. Section 5.3 Describes the Post-Development Water Budget including evaluation of the benefits of identified mitigation opportunities.

---

## 5.1 CLIMATE-BASED WATER BUDGET

The climate-based water budget calculations are included in Tables E-1 to E-3 (**Appendix E**) and are summarized in **Table 4**. The average annual precipitation for the thirty year normal data between 1981 and 2010 is about 886.2 mm/m<sup>2</sup>/year (mm/year). The annual potential evapotranspiration is calculated in Table E-1 at 575.9 mm/year. This equates to a potential water surplus of 394.8 mm/year and a soil moisture deficit of 84.5 mm/year. Thus the net annual water surplus based on potential evapotranspiration is 310.3 mm/year.

The calculations were expanded to include the water holding capacity of the soil as presented in Tables E-2 to E-3. This will produce a total moisture surplus based on the calculated actual evapotranspiration. Two (2) combinations of soil type and vegetation type were identified on the Site property for the Pre-Development and Post-Development scenarios. The majority of the surficial soil at the site is considered to be clay loam. The land use classifications and the corresponding water holding capacities are:

- Clay Loam, Residential Lawn (100 mm/year); and
- Clay Loam, Uncultivated (250 mm/year).

Consideration of these factors produces a range of net annual moisture surplus between 321.8 and 336.8 mm/year as summarized in **Table 4**. The soils with higher water holding capacity effectively increase the water removed as evapotranspiration.

The calculated moisture surplus occurs during the winter, spring and fall months, and a water deficit occurs during the summer months. Much of the water surplus in the winter accumulates as snow. Snowmelt during the spring results in the runoff or infiltration of precipitation that is effectively equivalent to the winter and spring water surplus.

---

## 5.2 PRE-DEVELOPMENT WATER BUDGET

The Pre-Development Water Budget was developed based on topographic information provided by Ontario Base Mapping and the Pre-Development Drainage Plan provided by Cole Engineering (Overall Development Plan).

---

### 5.2.1 PRE-DEVELOPMENT CATCHMENTS

A water balance for the larger development block was prepared by WSP in 2018. The calculations for this study considered the original study area. This analysis focusses on development Block 8, which is within the larger development block.

**Figure 9** illustrates the delineation of drainage catchments and sub-catchments for the pre-development condition at the Site. The Site is comprised of one internal (on-site) catchment. The catchment area has been further subdivided. The drainage sub-catchments are based on similar slopes, soils, and vegetation/land use. The drainage sub-catchments also include consideration of post-development drainage boundaries so that changes to drainage areas can be evaluated for the post-development conditions. The outlets for drainage of the identified Pre-Development catchment is as follows:

#### **On-Site Catchments:**

- **Pre-Development On-Site Catchment A:** Drains to the northwest via overland flow and is captured in the drainage ditches along both sides of Donland Lane. Runoff subsequently flows south along Donland Lane and exits the Site through the southern property boundary.

Table F-1 (**Appendix F**) provides a summary of the data attributes used to estimate the infiltration factor for each pre-development catchment and sub-catchment. The infiltration factor determined the proportion of the annual water surplus that would infiltrate or runoff within each sub-catchment.

---

### 5.2.2 PRE-DEVELOPMENT ANALYSIS

Properties associated with area, slope, soil type, and land cover were analyzed and assigned to each Pre-Development sub-catchment. The values assigned to each Pre-Development sub-catchment are provided in Table F-1 (**Appendix F**). These values were used to estimate an Infiltration Factor. The Infiltration Factors were reviewed to confirm that they are appropriate and adjusted if necessary. Existing paved areas were assumed to be impervious and to generate runoff equivalent to the precipitation volume minus a 10% evaporative loss.

Table F-1 includes the overall analysis of infiltration and runoff for the Site. Table F-1 also documents the calculation of volumes associated with input and output parameters for the Pre-Development conditions. These volumes are also expressed in terms of the number of mm of water within each sub-catchment area.

A summary of the Pre-Development water budget calculations is provided in **Table 5**. These values will be used to assess the changes that proposed development will create relative to the pre-development conditions.

---

### 5.2.3 PRE-DEVELOPMENT INFILTRATION

The estimated total infiltration for the Site is 2,216 m<sup>3</sup>/yr or an equivalent of 162 mm/year (mm/m<sup>2</sup>/yr). The calculated infiltration represents approximately 18.2% of the annual precipitation (886.2 mm/yr) and 40.5% of the calculated annual water surplus (399.2 mm/yr).

---

## 5.2.4 PRE-DEVELOPMENT RUNOFF

The total runoff for the Site is 3,256 m<sup>3</sup>/yr or an equivalent of 238 mm/year. The calculated runoff represents approximately 26.8% of the annual precipitation (886.2 mm/yr) and 59.5% of the estimated annual water surplus (399.2 mm/yr).

---

## 5.3 WATER BUDGET– POST-DEVELOPMENT CONDITIONS

The Post-Development Water Budget was based on the proposed site plan for development Block 8 as shown on **Figure 10**. The Post-Development scenario introduces six detached residential homes and a six (6)-storey residential condominium building including one (1) level underground parking garage and new roadways.

---

### 5.3.1 POST-DEVELOPMENT CATCHMENTS

Under post-development conditions, the Site has been subdivided into four (4) on-site catchments. Catchment and sub-catchment delineations in Pre-Development conditions were maintained for the Post-Development analysis.

Under Post-Development conditions, runoff from within the Site drains off-site via the on-site storm sewer system and overland flow. The outlets for each sub-catchment are summarized below:

#### **On-Site Catchments:**

- **Post-Development On-Site Catchment PA:** Drains off-site to the Barton SWM Pond (north of Site) via rear lot catch basins (RLCBs) and the on-site storm sewer system.
- **Post-Development On-Site Catchment PB:** Drains off-site to the Barton SWM Pond via the on-site storm sewer system.
- **Post-Development On-Site Catchment PC:** Drains off-site to the Barton SWM Pond via the on-site storm sewer system.
- **Post-Development On-Site Catchment PD:** Drains off-site to the Barton SWM Pond via the on-site storm sewer system.

Runoff from the developed areas in on-site catchment areas will be affected by the creation of buildings and driveway areas.

For the purpose of this analysis, Catchment PA is shown to generate runoff from rooftops and driveways that is inferred to be directed to the rear lot catchbasins. It is possible that some of this runoff from impervious surfaces may reach the ultimate outlet after being transferred via Catchment PB. This detail is not considered to change the finding of this analysis in terms of amount of runoff generated.

---

### 5.3.2 POST-DEVELOPMENT ANALYSIS

Properties associated with area, slope, soil type, and land cover were analyzed and assigned to each Post-Development sub-catchment. The values assigned to each Post-Development sub-catchment are provided in Table G-1 (**Appendix G**). These values were used to estimate an Infiltration Factor. The Infiltration Factors were reviewed to confirm that they are appropriate and adjusted if necessary.

Table G-1 includes the overall analysis of the total Study Area's infiltration and runoff. Table G-1 also documents the calculation of volumes associated with input and output parameters for the Post-Development condition. These volumes are also expressed in terms of the number of mm of water within each sub-catchment area. The volumes are summed by catchment and for the total property area.

Assumptions incorporated into the water budget for the Post-Development scenario included:

- 1) Impervious surfaces (roads, driveways and buildings) are assumed to have a 10% evaporative loss.

2) Runoff is assumed to be conveyed directly to the outlets and not infiltrated.

A summary of the Post-Development water budget calculations is provided in **Table 5**.

---

### 5.3.3 POST-DEVELOPMENT INFILTRATION

In the post-development condition, the Site will contain approximately 8,801 m<sup>2</sup> (64%) of impervious surfaces (44% roads, driveways and amenities and 20% building roofs). This would result in a net infiltration of 818 m<sup>3</sup>/year or 60 mm/yr. The net infiltration would reflect approximately 7% of the precipitation (886.2 mm/yr).

---

### 5.3.4 POST-DEVELOPMENT RUNOFF

The introduction of impervious surfaces will increase the total runoff from the developed area. The total runoff generated by the proposed development area is 7,837 m<sup>3</sup>/yr or 572 mm/year. The total calculated Post-Development runoff represents approximately 65% of the annual precipitation (886.2 mm/yr).

---

### 5.3.5 COMPARISON WITH PRE-DEVELOPMENT

**Table 5** provides a comparison of the water budget estimates for the Pre-Development and Post-Development cases. The total on-site infiltration is decreased by approximately 63% or 1,399 m<sup>3</sup>/yr. The introduction of additional impervious surfaces increases total runoff by 141% or 4,581 m<sup>3</sup>/yr. Review of Table G-1 (**Appendix G**) shows that approximately 40% of the post-development runoff comes from the road network (Catchment PB) and 41.5% comes from the area of the proposed condo building and associated parking area (Catchment PC). The runoff generated from the impervious surfaces in the post-development scenario has entirely been captured by the network of onsite catch basins and is redirected from the south property boundary to the Barton SWM Pond.

Part B of **Table 5** shows that approximately 2,239 m<sup>3</sup>/yr of runoff could be available from building rooftops for redirection to enhance infiltration within Block 8. Only 62% of this runoff would be required to off-set the infiltration deficit. Previous work on other parts of the development have identified challenges in demonstrating that enhanced infiltration can be achieved to fully off-set the deficit. This opportunity could potentially be investigated further, but experience with the low permeability of the native soils, high water table, and conditions associated with the proposed construction of underground parking suggest that there may only be potential to achieve a minor benefit associated with disconnection of roof leaders in the rear lots of the residential block. This benefit can be calculated on request.

LSRCA provides a program for developers to pay a fee to support initiatives to off-set infiltration within the LSRCA area in lieu of the effort and costs to design and implement measures to enhance infiltration.

---

## 5.4 WATER QUALITY

The water budget analysis must also consider potential changes to water quality that could be experienced in relation to the proposed development. The following sections describe the typical contaminants associated with the current and future land uses.

---

### 5.4.1 EXISTING CONDITIONS

The Site is currently vacant. As such, there are no activities present that could potentially impact groundwater quality at this time.

---

## 5.4.2 FUTURE CONDITIONS

The proposed Post-Development condition includes new driveway, parking lot, and roadway areas. These areas may be a future source of contamination to groundwater infiltration or surface water runoff by winter road de-icing agents. The most effective method of reducing potential impacts from salt or other winter road de-icing agents is to minimize the mass/volume of material applied through the use of Best Management Practices (BMPs). Any pervious areas used for winter snow storage may also become potential sources of contamination from winter road de-icing agents. BMPs recommend storing snow on impervious surfaces.

The driveway, parking lot, and roadway areas may also be a potential sources of petroleum hydrocarbons. These are typically contained in vehicles. The release of these substances will typically be the result of accidents. These potential releases could result in impairment of water quality by infiltrating into the groundwater. The risk of an accident occurring at the Site is low considering the only traffic will be the residents who occupy the building.

In pervious areas, soil-enrichment agents (i.e. fertilizers) and/or herbicides may also be a source of contamination. Application of these products should be minimized in order to reduce potential contamination.

# 6 DEWATERING ASSESSMENT

The potential requirements for dewatering in association with construction of the proposed residences and for long-term drainage from foundation drains is assessed below. The potential requirements for permitting associated with dewatering activities are as follows:

- Takings of less than 50,000 L/day at any one time do not require a permit;
- Takings of greater than 50,000 L/day but less than 400,000 L/day at any one time requires registration with the Environmental Activity and Sector Registry (EASR); or
- Takings of greater than 400,000 L/day at any one time for the project will require a Category 3 Permit to Take Water (PTTW).

WSP has prepared a preliminary assessment of the dewatering requirements and the associated impacts associated with construction and long-term drainage.

---

## 6.1 DEWATERING EQUATIONS AND ASSUMPTIONS

Given the subsurface conditions encountered in the study area, equations are used to account for excavations under unconfined groundwater conditions. For the purposes of these calculations, long narrow trench equations are assumed to be more appropriate to estimate flows for the foundation excavation, since the length to width ratio of the excavation is greater than 1.5.

### LONG NARROW TRENCH EQUATION – UNCONFINED CONDITIONS

Dewatering volumes were estimated using the following equation from Powers (1992) for drainage trench of finite length with a length to width ratio of greater than 1.5 for an unconfined system:

$$Q = \frac{xK(H^2 - h^2)}{\ln \frac{R_0}{r_s}} + 2 \left[ \frac{xK(H^2 - h^2)}{2L} \right]$$

where Q is discharge (m<sup>3</sup>/s), x is the trench sidewall length (m), K is hydraulic conductivity (m/s), H is initial water level (m), h is the required drawdown (m), R<sub>0</sub> is the equivalent radius of influence (m), and r<sub>s</sub> is the equivalent well radius (m). For more details, please refer to Powers (1992). Using the equation for a long, narrow system provides a more conservative estimate for dewatering rates when compared with using the equation for a drainage trench from a line source.



## DARCY'S LAW

Dewatering volumes for the calculation of seepage across the base of the excavation was estimated using the empirical Darcy's Law equation as described in Powers (1992):

$$Q = K_v A i$$

where Q is discharge (m<sup>3</sup>/s),  $K_v$  is vertical hydraulic conductivity (m/s), A is cross-sectional area (m<sup>2</sup>), and i is the hydraulic gradient.

## EQUIVALENT RADIUS OF INFLUENCE ( $R_0$ )

The equivalent radius of influence  $R_0$  is assumed to be equivalent to the zone of influence (ZOI).  $R_0$  was estimated using the empirical Sichart equation as described in Powers (1992):

$$R_0 = 3000(H - h)\sqrt{K}$$

where  $R_0$  is the equivalent radius of influence or ZOI (meters), H is the initial water level (meters), h is the required drawdown (meters), and K is hydraulic conductivity (meters/second).

---

## 6.2 ASSUMPTIONS

A number of assumptions were incorporated based on the site-specific data collected in site investigations and information about the proposed development. The assumptions related to construction dewatering are as follows:

- No measures are to be put in place to restrict flows into the excavations (e.g., sheet piling, caissons) to provide more conservative (overestimate) dewatering rates;
- The aquifer is uniform, continuous and of infinite extent;
- The proposed elevations of the building footing (October 2020) was provided to WSP by Keith Loffler Design Inc and McAlpine Architect Inc and are interpreted to range between 266.55 and 268.05 masl as presented in **Appendix D**. The condominium building basement footprint has been subdivided to represent three areas of footing elevations as presented in **Figure 12**. The footings for the main building are to be at 268.05 and the lower footings will be associated with the western part of the underground parking.
- The dimensions of each area used to estimate potential dewatering requirements are outlined below:
  - Area A – Proposed footing elevation of 266.55 masl – 53 x 18 m
  - Area B – Proposed footing elevation 267.05 masl – 9 x 18 m
  - Area C1 – Proposed footing elevation 268.05 masl – 62 x 22 m
  - Area C2 – Proposed footing elevation 268.05 masl – 22 x 19 m (for dewatering estimates, this section of the building basement is assumed to be rectangular in shape)
  - Area C3 – Proposed footing elevation 268.05 masl – 19 x 18 m
- Based on a review of the shallow soils observed during the Sola drilling, the majority of excavations for the building foundations are anticipated to be completed within the shallow layer soils described as fill. Conservative dewatering rates for excavation and long-term drainage were estimated using the estimated hydraulic conductivity for the shallow fill material, consisting of sand and some silt ( $6.20 \times 10^{-6}$  m/sec);
- For the purposes of estimating flux across the base of the excavation, vertical hydraulic conductivity was used in the calculation using the Darcy equation. The vertical hydraulic conductivity is assumed to be an order of magnitude lower than the horizontal hydraulic conductivity ( $6.20 \times 10^{-7}$  m/sec for the conservative dewatering rate);
- The vertical hydraulic gradient was assumed to be 0.1 m/m;
- Dewatering during construction is assumed to lower the water table by 1 m below the base of the footing;

- Assumed seasonal high groundwater elevations for the Site is based on elevations measured in April 2020. Based on the groundwater contours presented in **Figure 12**, the following average groundwater elevations within the subdivided building foundation areas were used in the dewatering estimates:
- Area A – 268.25 masl
- Area B – 269 masl
- Area C1 – 268.25 masl
- Area C2 – 269.25 masl
- Area C3 – 269.25 masl

Groundwater levels are typically at their highest level during the spring months (March -May) as the spring melt causes higher elevations than those experienced throughout the rest of the year. As such, WSP has used the measured groundwater levels on April 1, 2020 for the dewatering assessment.

- The required dewatering for the condominium was determined by comparing the average assumed seasonal high groundwater elevation to the proposed footing elevations for the building, and presented in **Figure 12**.

**Figure 13** has been prepared to illustrate the relative elevations of the proposed base of footings and the seasonal high water table in cross-section. The groundwater elevations observed during August 2020 are also shown on **Figure 13** to illustrate that groundwater elevations may not always be above the proposed footing elevations.

The primary factors that will control the rate of seepage into the excavation or foundations are the hydraulic conductivity and the depth that the water table will be lowered.

WSP notes that the available information on the groundwater elevations may reflect the presence of groundwater within the fill layer that is infiltrating down to the underlying strata. The hydraulic conductivity of this stratum is observed to be higher than the native soils beneath the proposed condominium. Information is not available to confirm that the groundwater will replenish the fill layer upon initiation of pumping. The calculations provided reflect a worst-case scenario where there is unlimited water available to enter the excavation. These estimates are likely to overestimate the actual rate of dewatering that will be experienced.

This assessment does not represent an engineering design of a dewatering operation, but a preliminary hydrogeological analysis for assessment of dewatering volumes. The actual design of the dewatering operation will be the responsibility of the contractor.

---

## 6.3 CONSTRUCTION DEWATERING CALCULATIONS

The calculations of the estimated volumes of water that could enter the excavations for the condominium is shown in **Table 6**. These calculations show the conservative dewatering rate that may be observed. Dewatering calculations are provided in **Appendix I**.

The total volume that would potentially need to be dewatered to maintain the entire area open to construct foundations at the same time is estimated to be up to 176,600 L/day, with an applied safety factor of 2. The zone of hydraulic influence from the excavation would be up to 38 m. Given the nature of the site, it is likely that hydraulic influence would extend off-site. Review of the conservatism in the estimates, and the effects of seasonality on potential impacts, it is prudent to register the proposed dewatering activity for the construction of foundations on the EASR and to manage activities such that daily dewatering volumes are maintained below 400,000 L/day.

The dewatering estimates provided herein address dewatering associated with construction of the building foundations and is intended to be conservative to reflect the maximum volume that could be experienced. These calculations only reflect potential dewatering requirements for construction of the building foundations. Additional dewatering may also be required to construct underground utilities. Ideally, work can be coordinated on the Site so that the combined daily flows from all dewatering can be managed to be less than 400,000 L/day such that a PTTW is not required.

WSP notes that the water table is observed in the soil unit described as fill or probable fill. The hydraulic conductivity of this layer is typically greater than the underlying native soils. As the fill layer is likely of limited lateral extent, there is potential that there may not be continuous influx of water into the excavation after it is opened and water is removed from storage.

---

## 6.4 LONG-TERM DRAINAGE

Much of the proposed foundation for the underground parking garage is anticipated to be continually below the seasonally high water table. A portion of the northeast corner of the proposed condominium building may not be continually submerged. As such, the construction design will either need to incorporate waterproofing measures or will require drainage systems to maintain dry foundations. It is possible that there may be reduced or no flow in dry seasons, particularly beneath the main building, but less likely beneath the northwestern portion of the parking garage.

The calculations of the estimated volume of water that could enter the foundation drains for the building block are shown in **Table 6**. These calculations show a conservative (maximum) seepage rate. Dewatering calculations for the long-term drainage scenario are provided in **Appendix I**.

The total volume that would potentially need to be drained to maintain dry conditions for the foundations would be up to 85,500 L/day with an applied safety factor of 2. The zone of hydraulic influence under this circumstance would be up to 30 m. It is likely that hydraulic influence would extend off-site.

Based on the volumes that are estimated for long-term drainage to maintain dry foundations, WSP recommends that the design of the condominium consider the use of a water proof basement that will not require continuous dewatering. As discussed below, continuous dewatering may not comply with Policy DEMD-1.

---

## 6.5 DEWATERING SUMMARY

The calculations of potential volumes of water that may require removal during construction or during long term use of the proposed structure are summarized in **Table 6**. The estimated pumping rate that may be experienced to maintain dry conditions during construction is up to 176,600 L/day. WSP recommends that the dewatering activity be registered on the EASR prior to construction. Additional groundwater quality testing is recommended to confirm suitability for discharge to nearby Region of Durham storm sewers.

Review of the water level data suggests that the majority of the foundation will be below the seasonally high water table. Water proofing of the basement/underground parking is recommended to reduce the potential that water is being removed and to thereby comply with Policy DEMD-1 (see below). The results of the ongoing groundwater monitoring program are recommended to be reviewed to confirm the relative positions of proposed foundation drains and the water table throughout the year.

The potential capacity of the Region of Durham storm sewers to receive these flows has not been evaluated as part of this preliminary evaluation. The estimated rate of pumping to maintain dry foundations will likely exceed 50,000 L/day, and therefore the construction activity will need to be registered on the EASR. An agreement with the Region of Durham will be required for discharge to be directed to the storm or sanitary sewers.

## 7 POLICY AREAS

The following sections discuss specific policy areas that pertain to groundwater resources and measures taken within the proposed development plan to conform to these policies.

### 7.1 WELLHEAD PROTECTION AREAS

The Durham Region Official Plan (DROP) delineates Wellhead Protection Areas (WHPA) for protection of the groundwater supplies that are used to provide the primary source of potable drinking water. The wellhead protection policies of the DROP conform to the requirements of the Oak Ridges Moraine Conservation Plan and are included in the Official Plan for the Township of Uxbridge. Section 1.9.6 of the Official Plan for the Township of Uxbridge states:

*Wellhead Protection Areas are designated on Schedule “L” to this Plan. They include lands that contribute water to municipal wells (capture zone). Land use restrictions shall be applied within Wellhead Protection Areas based on “time-of-travel” for groundwater to reach the municipal well and the relative threat posed by certain land use/activities in proximity to such wellheads. Land uses which pose a risk to the quality and quantity of groundwater in the wellhead protection areas are prohibited or restricted in accordance with Schedule ‘E’ – Tables ‘E5’ and ‘E6’ in the Durham Regional Official Plan and the policies of Section 2.3.25 to 2.3.28 inclusive of the Durham Regional Official Plan.*

In addition to the DROP, a Provincial initiative on Drinking Water Source Protection under *The Clean Water Act*, 2006 has been underway since 2006 to develop Drinking Water Source Protection Plans. *The Clean Water Act* provides regulations that define requirements for a “Risk Management Plan” that is not necessarily consistent with the DROP policies. A Risk Management Plan will only be required in areas where the Provincial Regulations under *The Clean Water Act*, 2006 apply. The WHPA and vulnerability scores from the Assessment Report for the Lakes Simcoe and Couchiching Source Protection Area are provided as **Figure 12**.

The Site does not lie within WHPA-A to D for the Town of Uxbridge wells as mapped under *The Clean Water Act*.

The Site does lie within the WHPA-Q1 and WHPA-Q2 areas that are mapped to identify the overall recharge areas for municipal wells and have assigned stress levels of moderate. Source Protection Plan (SPP) policies for WHPA-Q1 apply to areas where activities that take water without returning it to the same source may be a threat. SPP policies for WHPA-Q2 apply to areas where activities that reduce recharge might be a threat. As per the South Georgian Bay Lake Simcoe Protection Region, Approved Source Protection Plan, policy number DEMD-1 will apply to the water taking activities during dewatering for construction and long-term drainage.

Based on the estimated volumes of water that may require removal during construction and long-term drainage of the residential condominium, these activities will need to comply with policies for WHPA-Q1.

The proposed land use is residential and is not anticipated to present a threat to groundwater resources as per DROP Section 2.3.26.

---

### 7.2 HIGHLY VULNERABLE AQUIFERS

The Source Protection Plan for the Lakes Simcoe and Couchiching Source Protection Area, as developed to comply with *The Clean Water Act*, 2006, contains policies that apply to Highly Vulnerable Aquifers. **Figure 13** presents the mapping of Highly Vulnerable Aquifers (HVA) from the Assessment Report for the Lakes Simcoe and Couchiching Source Protection Area. HVA are considered to be susceptible to contamination of groundwater from activities on the surface or shallow subsurface. The proposed development area is mapped within an HVA area with a vulnerability score of 6.

The proposed development will be municipally serviced for sewage which will eliminate potential contamination of groundwater by nitrates and phosphorous. De-icing agents applied on impervious surfaces such as driveways and roadways will be collected by the on-site storm sewer system and released to the Barton SWM Pond. This will help

to minimize the amount of de-icing agents that infiltrate into the groundwater. Best management practices will likely require that the use of salt for winter road de-icing be minimized.

---

## 7.3 SIGNIFICANT GROUNDWATER RECHARGE AREAS

Policies 6.36 DP through 6.40 DP of the Lake Simcoe Protection Plan address significant Groundwater Recharge Areas (SGRA) and ecologically significant Groundwater Recharge Areas (ESGRA).

The Assessment Report for the Lakes Simcoe and Couchiching Source Protection Area contains mapping of Significant Groundwater Recharge Areas (SGRA). SGRA are regional areas that receive more than the average estimated recharge for a watershed area.

A very small portion of the Site is located within a SGRA with high vulnerability, as shown in **Figure 14**.

---

## 7.4 INTAKE PROTECTION ZONES

Intake Protection Zones (IPZ) refer to areas on the water and land surrounding a municipal surface water intake. The Site lies within an IPZ-3 with a score of 4.5 as shown on **Figure 15**. IPZ-3 includes areas that can be delineated if modelling demonstrates that spills from a specific activity that is located outside IPZ-1 and IPZ-2 may be transported to an intake and result in a deterioration of the water quality at an intake. In this case, there is potential for contaminants at the Site to be transported northward to Lake Simcoe and eventually to the water supply intakes around the Lake.

The majority of the runoff directed to Lake Simcoe leaves the Site to north after detention in the Barton stormwater management pond and is not likely to contain contaminants of concern. The potential for release of contaminants to surface water that will reach Lake Simcoe from the Site is minimal given the proposed residential land use. Winter road de-icing agents could potentially cause runoff contamination as the residence will include driveway and roadway areas. Mixing with clean runoff will reduce the concentration of these chemicals to an acceptable level prior to reaching Lake Simcoe and therefore the proposed activity does not present a water quality threat to the municipal surface water sources protected by the Source Protection Plan.

In addition, a vulnerability score between 8 and 10 is required to be considered a significant threat. The IPZ-3 has a vulnerability score of 4.5 and therefore activities associated with the development are not considered to be a significant threat.

# 8 CONCLUSIONS

- 1 WSP Canada Inc. (WSP) was retained by Evendale Developments Ltd. to prepare a Hydrogeological Assessment and Water Balance Study for the proposed residential development on Block 8 of Part of Lot 31, Concession 7, in the Township of Uxbridge (Site). The development plans for Block 8 include the streets, six (6) detached residential homes, and a six (6)-storey residential condominium building including one (1) level underground parking garage.
- 2 The proposed development area lies within the Peterborough Drumlin Field physiographic region as defined by Chapman and Putnam (1984). The Peterborough Drumlin Field is typically characterized by deposits of highly calcareous till, but the local area surrounding the Site is mapped as clay plains.
- 3 The on-site runoff generally drains to the northwest via overland flow, towards the proposed Lowe Blvd extension and is captured in the drainage ditch along Donland Lane.
- 4 Based on previous geotechnical investigations conducted at the Site the proposed development area is underlain by a shallow layer of topsoil which is followed by a layer heterogenous mixture of fill or probable fill ranging in texture from gravel, sand, silt and clay to a thickness of 2.3 to 3.1 m. The Fill overlies a layer of clayey silt to silty clay on the east side of the property and overlies layers of silty sand on the west side of the Site. This pattern is consistent with the surficial geology mapping presented on a regional scale and with stratigraphy information presented in water well records obtained through the MECP. The information presented in the Sola

borehole logs from review of physical samples does not confirm that the clayey silt to silty clay formation will typically overlie the silty sand formation but this is implied from regional stratigraphic understanding.

- 5 Seasonal high groundwater levels were observed in April 2020 in BH2 (268.61 masl) and BH5 (267.81 masl), and in January 2018 in MW1 (268.10 masl) and in MW2 (268.05 masl). The measured seasonally high groundwater levels correspond to depths of 1.59 mbgs at BH2, 1.49 mbgs at BH5, 0.13 mbgs at MW1 and 1.12 mbgs at MW2. Typically, groundwater levels are observed to be the highest between February and May and also in the late fall, while groundwater levels tend to be lowest between July and October. The observed groundwater levels generally follow the typical groundwater level trends.
- 6 The hydraulic conductivity estimates obtained from the on-site monitoring wells for the single well hydraulic response tests were  $9.84 \times 10^{-8}$  m/sec,  $6.20 \times 10^{-6}$  m/sec and  $4.01 \times 10^{-7}$  m/sec for BH2, BH5 and MW1, respectively. These results are consistent with the observed soil descriptions of the clayey silty at BH2, fill (sand) at BH5 and silty sand at MW1 in which the monitoring wells are screened. The hydraulic conductivity estimate obtained from the off-site monitoring well for the single well hydraulic response tests was  $4.90 \times 10^{-7}$  for MW2. This result is consistent with the observed soil descriptions of the silty sand at MW2 in which the monitoring wells are screened.
- 7 Two (2) groundwater samples were collected from the existing monitoring wells on February 14th, 2017. The concentrations of the parameters tested were less than the values of the MECP Table 2: Full Depth Generic Site Condition Standards in a Potable Ground Water Condition for All Types of Property Use (Coarse Textured Soil).
- 8 The Climate-Based Water Budget indicates that average annual precipitation over the past 30 years is 886.2 mm/year. The available moisture surplus at the Site ranges between 321.8 mm/yr to 336.8 mm/year depending on the type of soil and vegetation cover. The moisture surplus will reflect the infiltration and runoff based on the soil properties, slopes, and vegetation within individual catchments.
- 9 Under existing conditions, there is one (1) on-site catchment. Runoff generated on-site outlets to the northwest via overland flow and is captured in the drainage ditch along Donland Lane. Runoff subsequently flows south along Donland Lane and exits the Site through the southern property boundary.
- 10 The Pre-Development Water Budget reflects infiltration for the Site of approximately 2,216 m<sup>3</sup>/yr and runoff from the Site of approximately 3,256 m<sup>3</sup>/yr.
- 11 The Post-Development Water Budget reflects changes in land use to include increased areas of impervious surfaces (i.e. roads, buildings etc.) and re-grading. The proposed development area has been subdivided into four (4) on-site catchments. The majority of the runoff generated under post development conditions will be directed off-site to the Barton SWM Pond located approximately 500 m to the north of the Site via storm sewers.
- 12 The Post-Development Water Budget predicts a total on-site infiltration of 818 m<sup>3</sup>/yr. Overall, this is a decrease of 63% relative to the Pre-Development case, and represents an infiltration deficit of 1,399 m<sup>3</sup>/yr.
- 13 The Post-Development Water Budget predicts a net runoff of 7,837 m<sup>3</sup>/yr over the Site area. This is an increase of 141% or 4,581 m<sup>3</sup>/yr relative to the Pre-Development case. The runoff generated from the impervious surfaces in the post-development scenario has entirely been captured by the onsite catch basin and is redirected from the south property boundary to the Barton SWM Pond.
- 14 The estimated pumping rate that may be experienced to maintain dry conditions during construction is up to 176,600 L/day. WSP recommends that the dewatering activity be registered on the EASR prior to construction. Additional groundwater quality testing is recommended to confirm suitability for discharge to nearby Region of Durham storm sewers.
- 15 The majority of the proposed footing elevations are below the seasonally high water table. Estimates of the dewatering rates to maintain dry foundations are up to 85,500 L/day, including a 2X factor of safety. Water proofing of the basement/underground parking is recommended to reduce the potential that water is being removed and to thereby comply with Policy DEMD-1.
- 16 The Site lies within WHPA-Q1 and WHPA-Q2 for the Uxbridge Water Supply system with assigned stress levels of moderate. Source Protection Plan (SPP) policies for WHPA-Q1 apply to areas where activities that take water without returning it to the same source may be a threat. SPP policies for WHPA-Q2 apply to areas where activities that reduce recharge might be a threat. Based on the estimated volumes of water that may require removal during construction and long-term drainage of the residential condominium, the Site will need to comply further with policies for WHPA-Q1. As per the South Georgian Bay Lake Simcoe Protection Region, Approved Source Protection Plan, policy number DEMD-1 will apply to the water taking activities during

dewatering for construction and long-term drainage. Policies associated with WHPA – Q2 may apply to offset identified infiltration deficit relative to pre-development conditions.

- 17 The proposed development area is mapped within a Highly Vulnerable Aquifer (HVA) area with a vulnerability score of 6. The Site will be municipally serviced for sewage which will eliminate potential contamination of groundwater by nitrates and phosphorous. De-icing agents applied on impervious surfaces such as driveways and roadways will be collected by the on-site storm sewer system and released to the Barton SWM Pond. This will help to minimize the amount of de-icing agents that infiltrate into the groundwater. Best management practices will likely require that the use of salt for winter road de-icing be minimized.
- 18 The proposed development is located within a Significant Groundwater Recharge Area with a vulnerability score of 6.
- 19 The Site lies within Intake Protection Zone 3 (IPZ-3) for Lake Simcoe. The majority of the runoff directed to Lake Simcoe leaves the Site to north after detention in the Barton stormwater management pond and is not likely to contain contaminants of concern. The potential for release of contaminants to surface water that will reach Lake Simcoe from the Site is minimal given the proposed residential land use. Winter road de-icing agents could potentially cause runoff contamination as the residence will include driveway and roadway areas. Mixing with clean runoff will reduce the concentration of these chemicals to an acceptable level prior to reaching Lake Simcoe and therefore the proposed activity does not present a water quality threat to the municipal surface water sources protected by the Source Protection Plan.

This concludes the Hydrogeological Assessment and Water Balance Study. We trust that this report satisfies your requirements. If you have any questions or concerns regarding this report, do not hesitate to contact our office.

## 9 REFERENCES

- Armstrong, D.K., and Dodge, J.E.P., 2007. Paleozoic Geology of Southern Ontario - Project Summary and Technical Document, Ontario Geological Survey, Miscellaneous Release – Data 219.
- Chapman, L.J. and D.F. Putnam, 1984. The Physiography of Southern Ontario. Ontario Geological Survey, Third Edition. 270 pp. Accompanied by Map P.2715, Scale 1:600,000.
- Cole Engineering Group Ltd, 2017. Functional Servicing and Stormwater Management Report, Brock Street East Development, Township of Uxbridge.
- Gao, C., Shiota, J., Kelly, R.I., Brunton, F.R., and van Haaften, S., 2006. Bedrock Topography and overburden thickness mapping, southern Ontario, Ontario Geological Survey, Miscellaneous Release – Data 207.
- Hvorslev, M.J., 1951. Time Lag and Soil Permeability in Ground-Water Observations. Bulletin No. 36. Waterways Experiment Station, U.S. Army Corps of Engineers, Vicksburg, Mississippi.
- Kassenaar, J.D.C. and Wexler, E.J., 2006. Groundwater Modelling of the Oak Ridges Moraine Area. CAMC-YPDT Technical Report #01-06.
- LSRCA. May 2019. Lake Simcoe Protection Plan Water Budget Offsetting Policy for LSPP 4.8-DP and 6.40-DP.
- Ontario Geological Survey, 2011. 1:250,000 Scale Bedrock Geology of Ontario, Ontario Geological Survey Miscellaneous Release – Data 126- Revision 1.
- Ontario Ministry of the Environment, 2008. Design Guidelines for Sewage Works.
- Ontario Ministry of the Environment and Energy. 1995. Hydrological Technical Information Requirements for Land Development Applications.
- Russell, H.A.J., Sharpe, D.R., and Logan, C. 2005: Structural Model of the Greater Toronto and Oak Ridges Moraine Areas, Southern Ontario: Halton Till; Geological Survey of Canada, Open File 5064, scale 1:250,000.
- Russell, H.A.J., Sharpe, D.R., and Logan, C. 2005: Structural Model of the Greater Toronto and Oak Ridges Moraine Areas, Southern Ontario: ORM Sediment; Geological Survey of Canada, Open File 5065, scale 1:250,000.
- Sharpe, D.R., Russell, H.A.J., and Logan, C. 2005: Structural Model of the Greater Toronto and Oak Ridges Moraine Areas, Southern Ontario: Lower Sediment, Geological Survey of Canada, Open File 5067, scale 1:250,000.
- Sharpe, D.R., Russell, H.A.J., and Logan, C. 2005. Structural Model of the Greater Toronto and Oak Ridges Moraine Areas, Southern Ontario: Newmarket Till, Geological Survey of Canada, Open File 5066, scale 1:250,000.
- Sola Engineering Inc, 2020. Geotechnical Investigation, Proposed Apartment Development, Brock Street East and Herrema Boulevard, Uxbridge, Ontario.
- WSP Canada Inc, 2020. Hydrogeological Assessment and Water Balance Study, Block 6 – Part of Lot 31, Concession 7, Uxbridge.
- WSP Canada Inc, 2018. Hydrogeological Assessment and Water Balance Study, Part of Lot 31, Concession 7, Uxbridge.



## Drawings Appendix



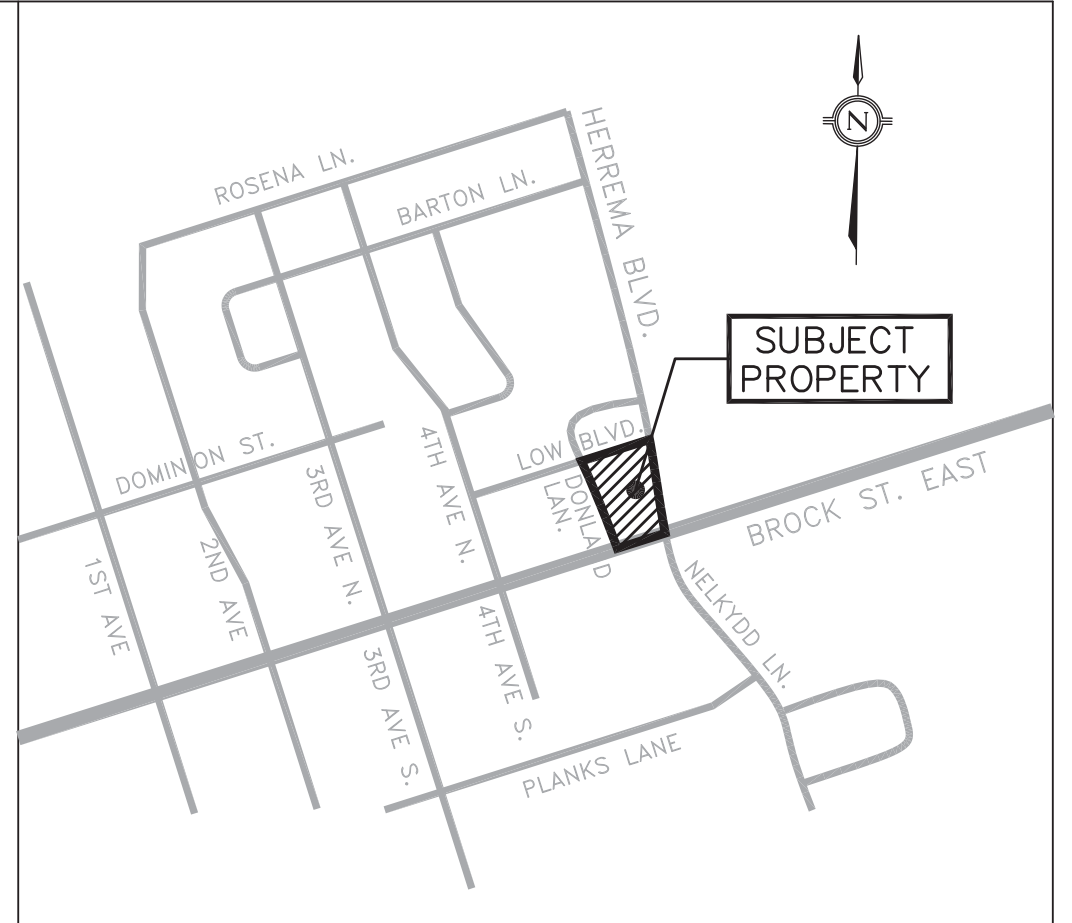
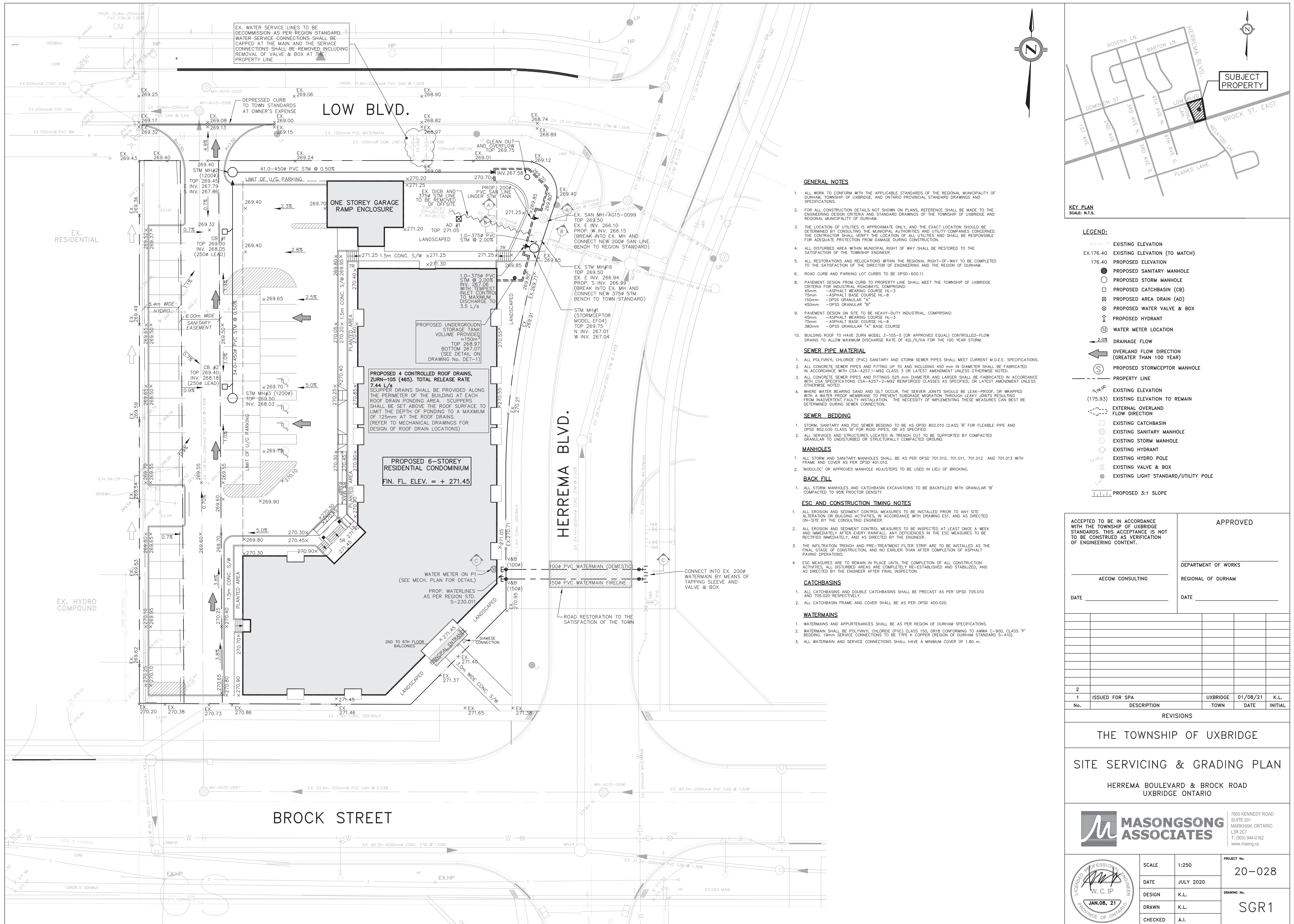

- GENERAL NOTES**
1. ALL WORK TO CONFORM WITH THE APPLICABLE STANDARDS OF THE REGIONAL MUNICIPALITY OF DURHAM, TOWNSHIP OF UXBRIDGE, AND ONTARIO PROVINCIAL STANDARD DRAWINGS AND SPECIFICATIONS.
  2. FOR ALL CONSTRUCTION DETAILS NOT SHOWN ON PLANS, REFERENCE SHALL BE MADE TO THE ENGINEERING DESIGN CRITERIA AND STANDARD DRAWINGS OF THE TOWNSHIP OF UXBRIDGE AND REGIONAL MUNICIPALITY OF DURHAM.
  3. THE LOCATION OF UTILITIES IS APPROXIMATE ONLY, AND THE EXACT LOCATION SHOULD BE DETERMINED BY CONSULTING THE MUNICIPAL AUTHORITIES AND UTILITY COMPANIES CONCERNED. THE CONTRACTOR SHALL VERIFY THE LOCATION OF ALL UTILITIES AND SHALL BE RESPONSIBLE FOR ADEQUATE PROTECTION FROM DAMAGE DURING CONSTRUCTION.
  4. ALL DISTURBED AREA WITHIN MUNICIPAL RIGHT OF WAY SHALL BE RESTORED TO THE SATISFACTION OF THE TOWNSHIP ENGINEER.
  5. ALL RESTORATIONS AND RELOCATIONS WITHIN THE REGIONAL RIGHT-OF-WAY TO BE COMPLETED TO THE SATISFACTION OF THE DIRECTOR OF ENGINEERING AND THE REGION OF DURHAM.
  6. ROAD CURB AND PARKING LOT CURBS TO BE OPSD-600.11.
  7. PAVEMENT DESIGN FROM CURB TO PROPERTY LINE SHALL MEET THE TOWNSHIP OF UXBRIDGE CRITERIA FOR INDUSTRIAL ROADWAYS, COMPRISING:
    - 45mm - ASPHALT WEARING COURSE HL-3
    - 75mm - ASPHALT BASE COURSE HL-8
    - 150mm - OPSS GRANULAR "A"
    - 450mm - OPSS GRANULAR "B"
  8. PAVEMENT DESIGN ON SITE TO BE HEAVY-DUTY INDUSTRIAL, COMPRISING:
    - 45mm - ASPHALT WEARING COURSE HL-3
    - 75mm - ASPHALT BASE COURSE HL-8
    - 380mm - OPSS GRANULAR "A" BASE COURSE
  9. BUILDING ROOF TO HAVE ZURN MODEL Z-105-5 (OR APPROVED EQUAL) CONTROLLED-FLOW DRAINS TO ALLOW MAXIMUM DISCHARGE RATE OF 42L/S/HA FOR THE 100 YEAR STORM.

- SEWER PIPE MATERIAL**
1. ALL POLYVINYL CHLORIDE (PVC) SANITARY AND STORM SEWER PIPES SHALL MEET CURRENT M.O.E.E. SPECIFICATIONS.
  2. ALL CONCRETE SEWER PIPES AND FITTING UP TO AND INCLUDING 450 mm IN DIAMETER SHALL BE FABRICATED IN ACCORDANCE WITH CSA-A257.1-M92 CLASS 3 OR LATEST AMENDMENT UNLESS OTHERWISE NOTED.
  3. ALL CONCRETE SEWER PIPES AND FITTINGS 525 mm DIAMETER AND LARGER SHALL BE FABRICATED IN ACCORDANCE WITH CSA SPECIFICATIONS CSA-A257-2-M92 REINFORCED CLASSES AS SPECIFIED, OR LATEST AMENDMENT UNLESS OTHERWISE NOTED.
  4. WHERE WATER BEARING SAND AND SILT OCCUR, THE SEWER JOINTS SHOULD BE LEAK-PROOF, OR WRAPPED WITH A WATER PROOF MEMBRANE TO PREVENT SUBGRADE MIGRATION THROUGH LEAKY JOINTS RESULTING FROM INADEQUATE FAULTY INSTALLATION. THE NECESSITY OF IMPLEMENTING THESE MEASURES CAN BE DETERMINED DURING SEWER CONNECTION.

- SEWER BEDDING**
1. STORM, SANITARY AND FDC SEWER BEDDING TO BE AS OPSD 802.010 CLASS "B" FOR FLEXIBLE PIPE AND OPSD 802.030 CLASS "B" FOR RIGID PIPES, OR AS SPECIFIED.
  2. ALL SERVICES AND STRUCTURES LOCATED IN TRENCH CUT TO BE SUPPORTED BY COMPACTED GRANULAR TO UNDISTURBED OR STRUCTURALLY COMPACTED GROUND.

- MANHOLES**
1. ALL STORM AND SANITARY MANHOLES SHALL BE AS PER OPSD 701.010, 701.011, 701.012 AND 701.013 WITH FRAME AND COVER AS PER OPSD 701.010.
  2. "MODULOC" OR APPROVED MANHOLE ADJUSTERS TO BE USED IN LIEU OF BRICKING.

- BACK FILL**
1. ALL STORM MANHOLES AND CATCHBASIN EXCAVATIONS TO BE BACKFILLED WITH GRANULAR "B" COMPACTED TO 95% PROCTOR DENSITY.

- ESC AND CONSTRUCTION TIMING NOTES**
1. ALL EROSION AND SEDIMENT CONTROL MEASURES TO BE INSTALLED PRIOR TO ANY SITE ALTERATION OR BUILDING ACTIVITIES, IN ACCORDANCE WITH DRAWING ESI, AND AS DIRECTED ON-SITE BY THE CONSULTING ENGINEER.
  2. ALL EROSION AND SEDIMENT CONTROL MEASURES TO BE INSPECTED AT LEAST ONCE A WEEK AND IMMEDIATELY AFTER EVERY RAINFALL. ANY DEFICIENCIES IN THE ESC MEASURES TO BE RECTIFIED IMMEDIATELY, AND AS DIRECTED BY THE ENGINEER.
  3. THE INFILTRATION TRENCH AND PRE-TREATMENT FILTER STRIP ARE TO BE INSTALLED AS THE FINAL STAGE OF CONSTRUCTION, AND NO EARLIER THAN AFTER COMPLETION OF ASPHALT PAVING OPERATIONS.
  4. ESC MEASURES ARE TO REMAIN IN PLACE UNTIL THE COMPLETION OF ALL CONSTRUCTION ACTIVITIES. ALL DISTURBED AREAS ARE COMPLETELY RE-ESTABLISHED AND STABILIZED, AND AS DIRECTED BY THE ENGINEER AFTER FINAL INSPECTION.

- CATCHBASINS**
1. ALL CATCHBASINS AND DOUBLE CATCHBASINS SHALL BE PRECAST AS PER OPSD 705.010 AND 705.020 RESPECTIVELY.
  2. ALL CATCH-BASIN FRAME AND COVER SHALL BE AS PER OPSD 400.020.

- WATERMANS**
1. WATERMANS AND APPURTENANCES SHALL BE AS PER REGION OF DURHAM SPECIFICATIONS.
  2. WATERMAN SHALL BE POLYVINYL CHLORIDE (PVC) CLASS 150, DR18 CONFORMING TO AWWA C-900, CLASS "B" BEDDING. 18mm SERVICE CONNECTIONS TO BE TYPE K COPPER (REGION OF DURHAM STANDARD S-410).
  3. ALL WATERMAIN AND SERVICE CONNECTIONS SHALL HAVE A MINIMUM COVER OF 1.80 m.

KEY PLAN  
SCALE: N.T.S.

**LEGEND:**

- EXISTING ELEVATION
- EXISTING ELEVATION (TO MATCH)
- PROPOSED ELEVATION
- PROPOSED SANITARY MANHOLE
- PROPOSED STORM MANHOLE
- PROPOSED CATCHBASIN (CB)
- ⊠ PROPOSED AREA DRAIN (AD)
- ⊕ PROPOSED WATER VALVE & BOX
- ⊕ PROPOSED HYDRANT
- ⊕ WATER METER LOCATION
- 2.0% DRAINAGE FLOW
- OVERLAND FLOW DIRECTION (GREATER THAN 100 YEAR)
- PROPOSED STORMRECEPTOR MANHOLE
- PROPERTY LINE
- EXISTING ELEVATION (175.93)
- EXISTING ELEVATION TO REMAIN
- EXISTING CATCHBASIN
- EXISTING SANITARY MANHOLE
- EXISTING STORM MANHOLE
- EXISTING HYDRANT
- EXISTING HYDRO POLE
- EXISTING VALVE & BOX
- EXISTING LIGHT STANDARD/UTILITY POLE
- ▭ PROPOSED 3:1 SLOPE

ACCEPTED TO BE IN ACCORDANCE WITH THE TOWNSHIP OF UXBRIDGE STANDARDS. THIS ACCEPTANCE IS NOT TO BE CONSTRUED AS VERIFICATION OF ENGINEERING CONTENT.		APPROVED	
AECOM CONSULTING		DEPARTMENT OF WORKS	
REGIONAL OF DURHAM		DATE	
DATE		DATE	

REVISIONS			
No.	DESCRIPTION	TOWN	INITIAL
2	ISSUED FOR SPA	UXBRIDGE	01/08/21 K.L.

THE TOWNSHIP OF UXBRIDGE

SITE SERVICING & GRADING PLAN

HERREMA BOULEVARD & BROCK ROAD  
UXBRIDGE ONTARIO

<p><b>MASONGSONG ASSOCIATES</b></p> <p>7800 KENNEDY ROAD SUITE 201 MARRHAM, ONTARIO L3R 2C7 T: (905) 944-0162 www.masongsong.ca</p>	SCALE	1:250	PROJECT No.	20-028
	DATE	JULY 2020	DRAWING No.	SGR1
	DESIGN	K.L.	CHECKED	A.I.

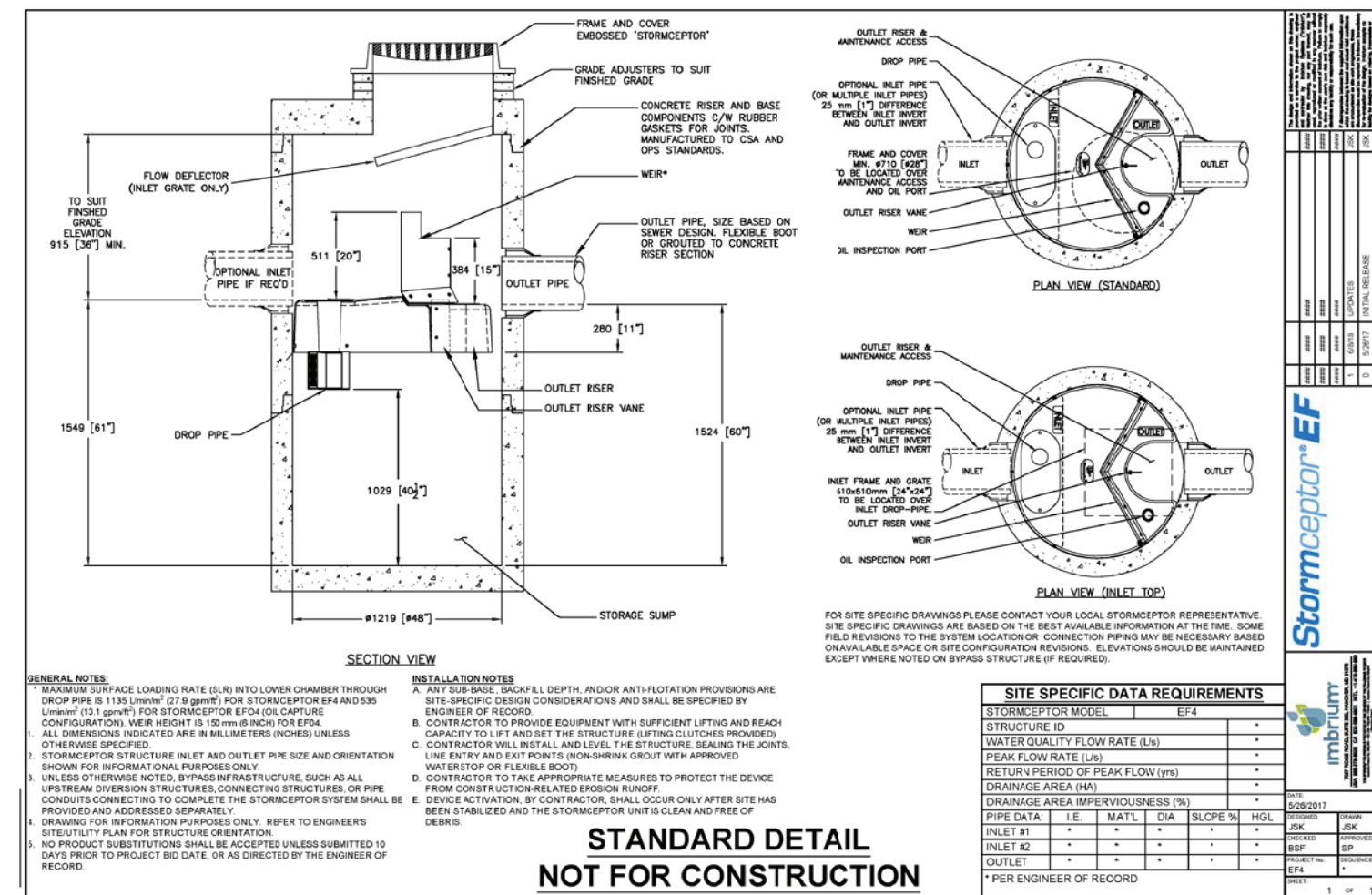
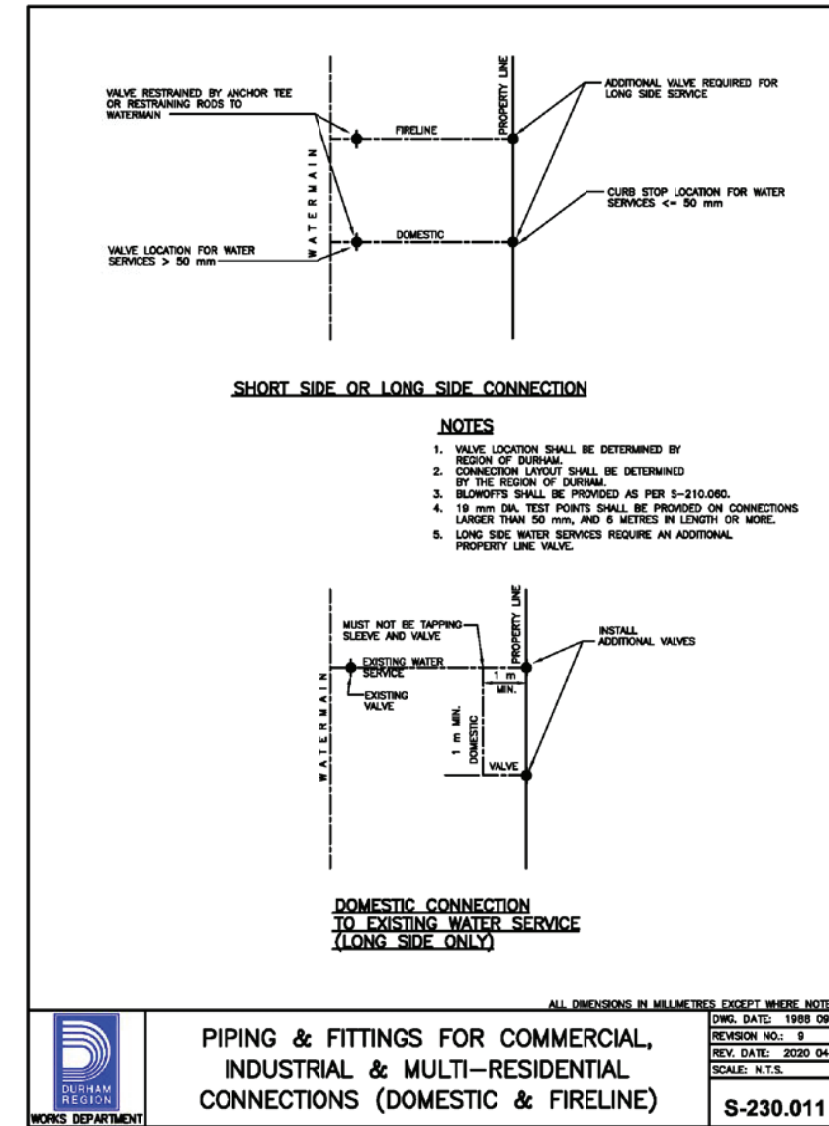
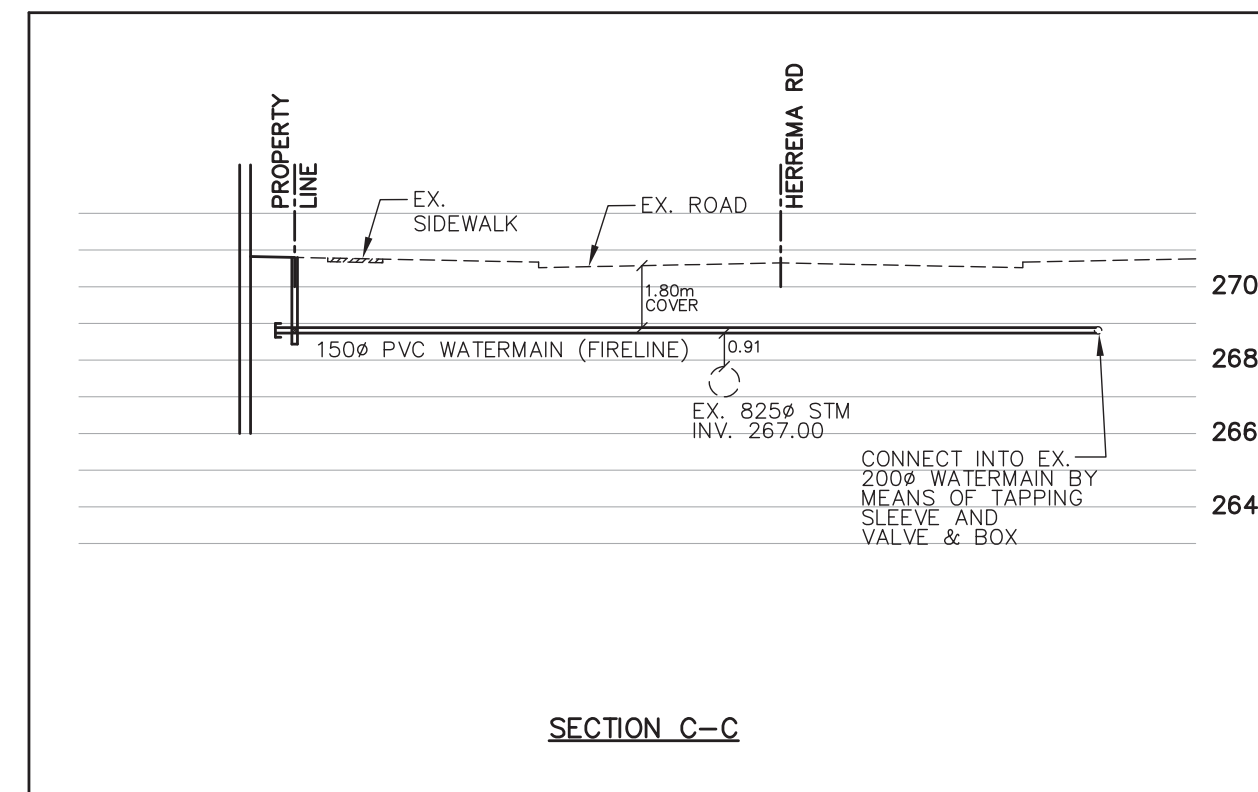
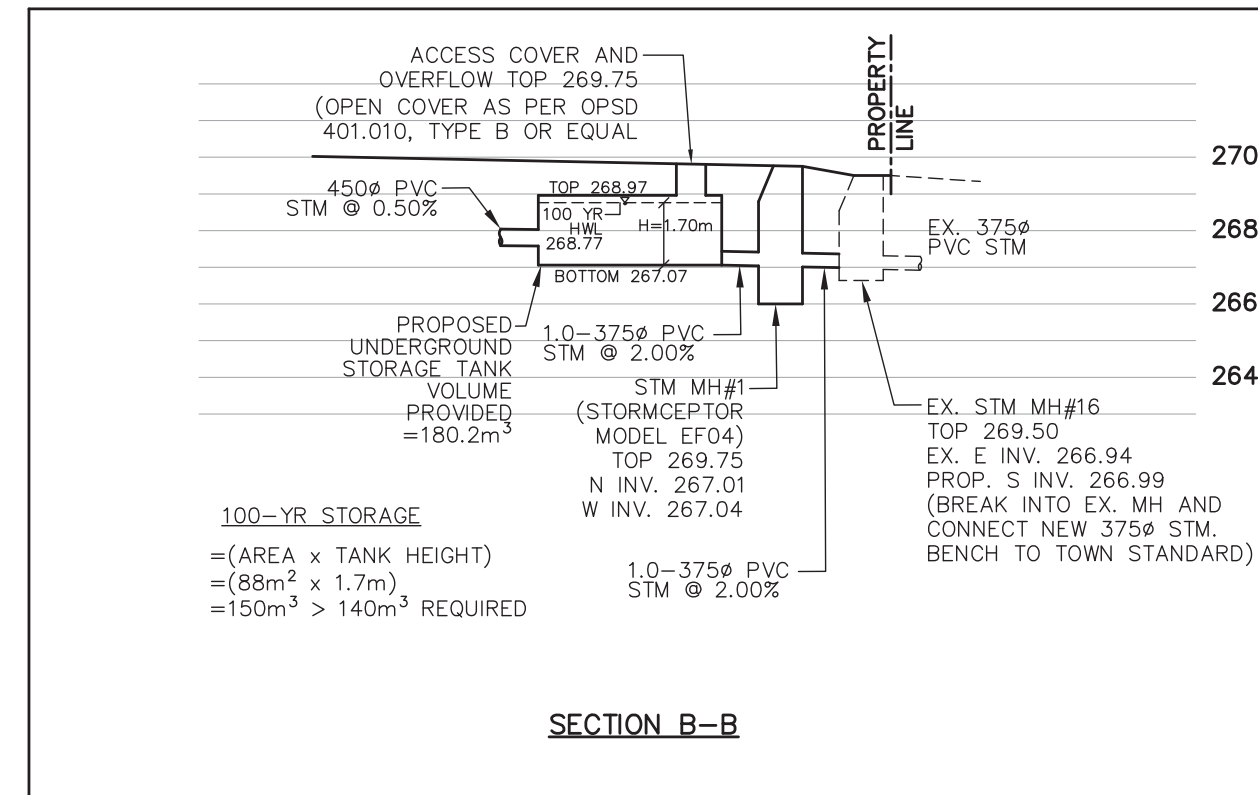
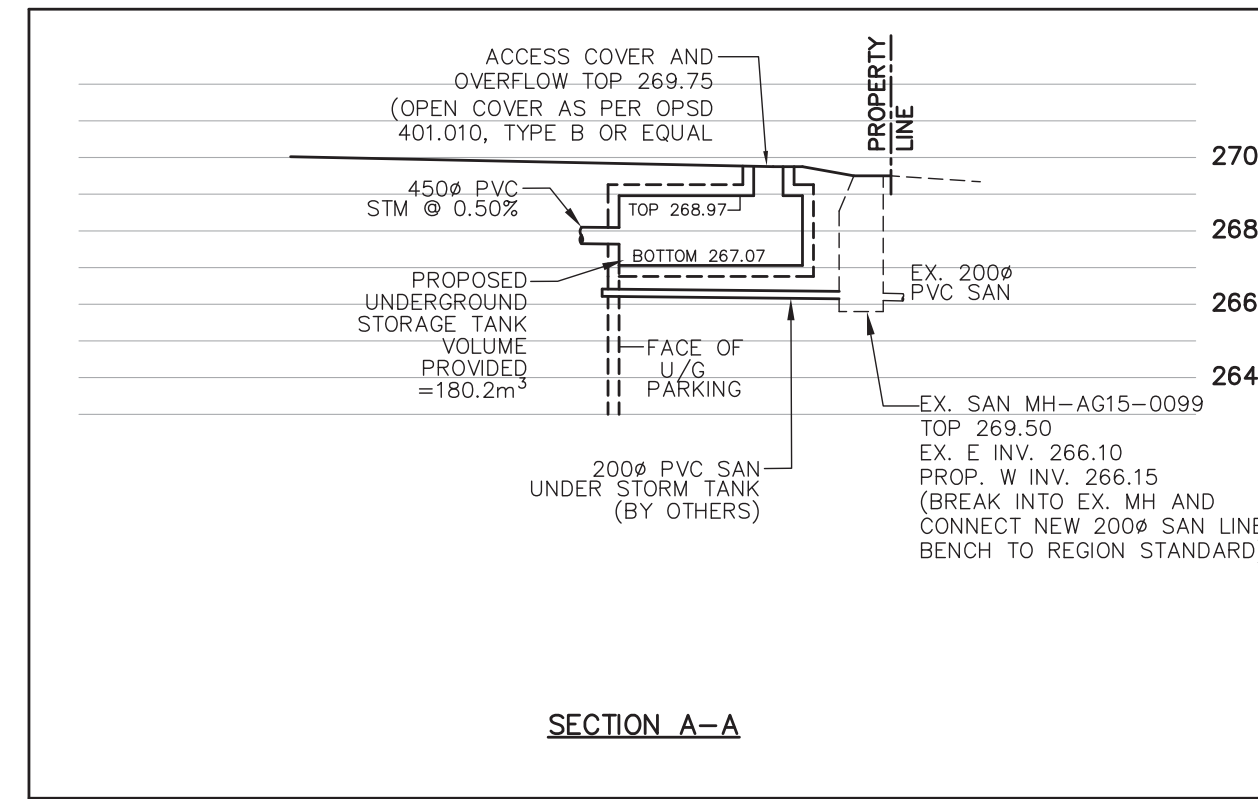

**GENERAL NOTES**

- ALL WORK TO CONFORM WITH THE APPLICABLE STANDARDS OF THE REGIONAL MUNICIPALITY OF DURHAM, TOWNSHIP OF UXBRIDGE, AND ONTARIO PROVINCIAL STANDARD DRAWINGS AND SPECIFICATIONS.
- FOR ALL CONSTRUCTION DETAILS NOT SHOWN ON PLANS, REFERENCE SHALL BE MADE TO THE ENGINEERING DESIGN CRITERIA AND STANDARD DRAWINGS OF THE TOWNSHIP OF UXBRIDGE AND REGIONAL MUNICIPALITY OF DURHAM.
- THE LOCATION OF UTILITIES IS APPROXIMATE ONLY, AND THE EXACT LOCATION SHOULD BE DETERMINED BY CONSULTING THE MUNICIPAL AUTHORITIES AND UTILITY COMPANIES CONCERNED. THE CONTRACTOR SHALL VERIFY THE LOCATION OF ALL UTILITIES AND SHALL BE RESPONSIBLE FOR ADEQUATE PROTECTION FROM DAMAGE DURING CONSTRUCTION.
- ALL DISTURBED AREA WITHIN MUNICIPAL RIGHT OF WAY SHALL BE RESTORED TO THE SATISFACTION OF THE TOWNSHIP ENGINEER.
- ALL RESTORATIONS AND RELOCATIONS WITHIN THE REGIONAL RIGHT-OF-WAY TO BE COMPLETED TO THE SATISFACTION OF THE DIRECTOR OF ENGINEERING AND THE REGION OF DURHAM.
- ROAD CURB AND PARKING LOT CURBS TO BE OPSD-600.11.
- PAVEMENT DESIGN FROM CURB TO PROPERTY LINE SHALL MEET THE TOWNSHIP OF UXBRIDGE CRITERIA FOR INDUSTRIAL ROADWAYS, COMPRISING:
  - 45mm - ASPHALT WEARING COURSE HL-3
  - 75mm - ASPHALT BASE COURSE HL-8
  - 150mm - OPSD GRANULAR "A"
  - 450mm - OPSD GRANULAR "B"
- PAVEMENT DESIGN ON SITE TO BE HEAVY-DUTY INDUSTRIAL, COMPRISING:
  - 45mm - ASPHALT WEARING COURSE HL-3
  - 75mm - ASPHALT BASE COURSE HL-8
  - 380mm - OPSD GRANULAR "A" BASE COURSE
- BUILDING ROOF TO HAVE ZURN MODEL Z-105-S (OR APPROVED EQUAL) CONTROLLED-FLOW DRAINS TO ALLOW MAXIMUM DISCHARGE RATE OF 42L/S/HA FOR THE 100 YEAR STORM.

**SEWER PIPE MATERIAL**

- ALL POLYVINYL CHLORIDE (PVC) SANITARY AND STORM SEWER PIPES SHALL MEET CURRENT M.O.E.E. SPECIFICATIONS.
- ALL CONCRETE SEWER PIPES AND FITTINGS UP TO AND INCLUDING 450 mm IN DIAMETER SHALL BE FABRICATED IN ACCORDANCE WITH CSA-A257.1-M92 CLASS 3 OR LATEST AMENDMENT UNLESS OTHERWISE NOTED.
- ALL CONCRETE SEWER PIPES AND FITTINGS 525 mm DIAMETER AND LARGER SHALL BE FABRICATED IN ACCORDANCE WITH CSA SPECIFICATIONS CSA-A257-2-M92 REINFORCED CLASSES AS SPECIFIED, OR LATEST AMENDMENT UNLESS OTHERWISE NOTED.
- WHERE WATER BEARING SAND AND SILT OCCUR, THE SEWER JOINTS SHOULD BE LEAK-PROOF, OR WRAPPED WITH A WATER PROOF MEMBRANE TO PREVENT SUBGRADE MIGRATION THROUGH LEAKY JOINTS RESULTING FROM INADEQUATE FAULTY INSTALLATION. THE NECESSITY OF IMPLEMENTING THESE MEASURES CAN BEST BE DETERMINED DURING SEWER CONNECTION.

**SEWER BEDDING**

- STORM, SANITARY AND FDC SEWER BEDDING TO BE AS PER OPSD 802.010 CLASS "B" FOR FLEXIBLE PIPE AND OPSD 802.030 CLASS "B" FOR RIGID PIPES, OR AS SPECIFIED.
- ALL SERVICES AND STRUCTURES LOCATED IN TRENCH OUT TO BE SUPPORTED BY COMPACTED GRANULAR TO UNDISTURBED OR STRUCTURALLY COMPACTED GROUND.

**MANHOLES**

- ALL STORM AND SANITARY MANHOLES SHALL BE AS PER OPSD 701.010, 701.011, 701.012 AND 701.013 WITH FRAME AND COVER AS PER OPSD 400.010.
- "MODULOC" OR APPROVED MANHOLE ADJUSTERS TO BE USED IN LIEU OF BRICKING.

**BACK FILL**

- ALL STORM MANHOLES AND CATCHBASIN EXCAVATIONS TO BE BACKFILLED WITH GRANULAR "B" COMPACTED TO 95% PROCTOR DENSITY.

**ESC AND CONSTRUCTION TIMING NOTES**

- ALL EROSION AND SEDIMENT CONTROL MEASURES TO BE INSTALLED PRIOR TO ANY SITE ALTERATION OR BUILDING ACTIVITIES, IN ACCORDANCE WITH DRAWING EST, AND AS DIRECTED ON-SITE BY THE CONSULTING ENGINEER.
- ALL EROSION AND SEDIMENT CONTROL MEASURES TO BE INSPECTED AT LEAST ONCE A WEEK AND IMMEDIATELY AFTER EVERY RAINFALL. ANY DEFICIENCIES IN THE ESC MEASURES TO BE RECTIFIED IMMEDIATELY, AND AS DIRECTED BY THE ENGINEER.
- THE INFILTRATION TRENCH AND PRE-TREATMENT FILTER STRIP ARE TO BE INSTALLED AS THE FINAL STAGE OF CONSTRUCTION, AND NO EARLIER THAN AFTER COMPLETION OF ASPHALT PAVING OPERATIONS.
- ESC MEASURES ARE TO REMAIN IN PLACE UNTIL THE COMPLETION OF ALL CONSTRUCTION ACTIVITIES. ALL DISTURBED AREAS ARE COMPLETELY RE-ESTABLISHED AND STABILIZED, AND AS DIRECTED BY THE ENGINEER AFTER FINAL INSPECTION.

**CATCHBASINS**

- ALL CATCHBASINS AND DOUBLE CATCHBASINS SHALL BE PRECAST AS PER OPSD 705.010 AND 705.020 RESPECTIVELY.
- ALL CATCH-BASIN FRAME AND COVER SHALL BE AS PER OPSD 400.020.

**WATERMAINS**

- WATERMAINS AND APPURTENANCES SHALL BE AS PER REGION OF DURHAM SPECIFICATIONS.
- WATERMAIN SHALL BE POLYVINYL CHLORIDE (PVC) CLASS 150, DRIP CONFORMING TO AWWA C-900, CLASS "P" BEDDING, 19mm SERVICE CONNECTIONS TO BE TYPE K COPPER (REGION OF DURHAM STANDARD S-410).
- ALL WATERMAIN AND SERVICE CONNECTIONS SHALL HAVE A MINIMUM COVER OF 1.80 m.

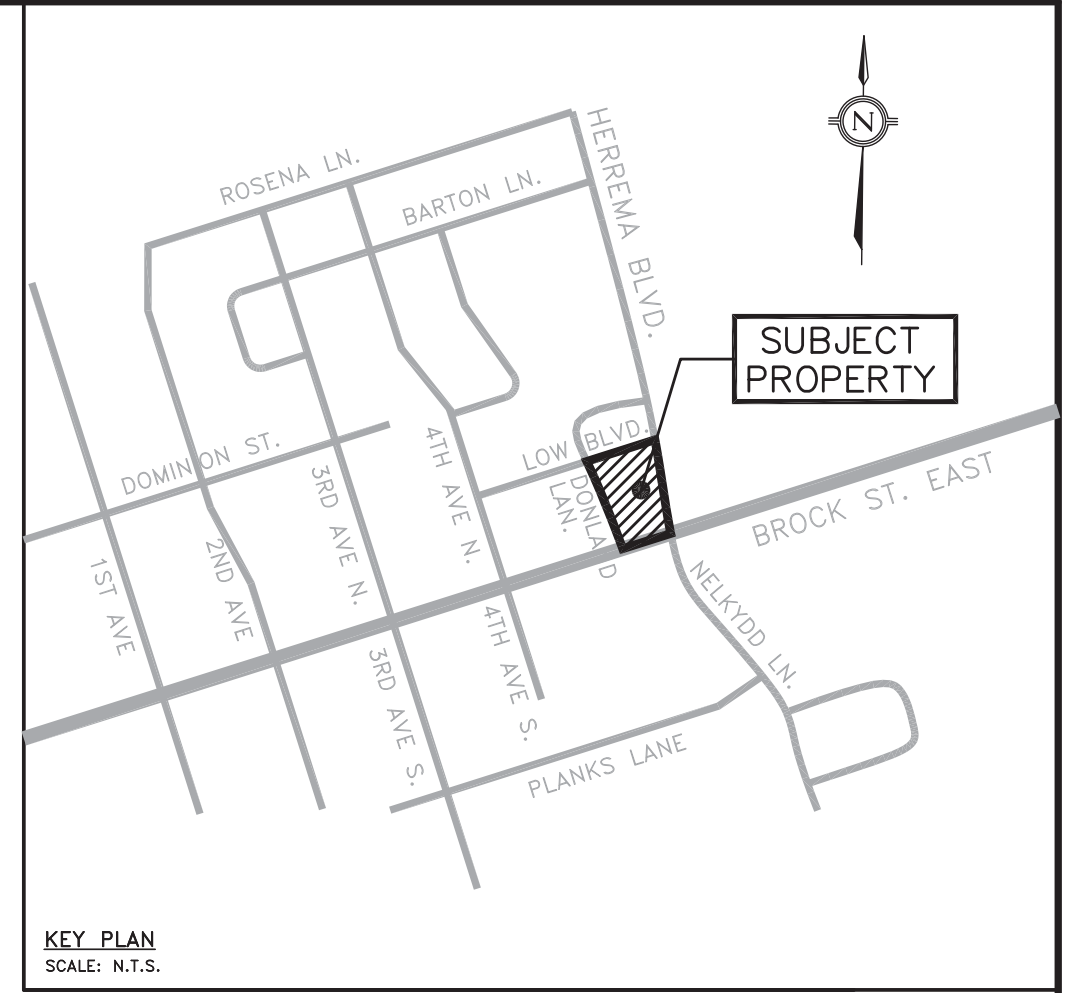
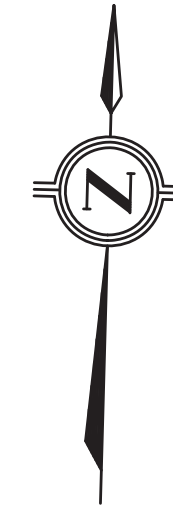

KEY PLAN  
SCALE: 1:1.5

ACCEPTED TO BE IN ACCORDANCE WITH THE TOWNSHIP OF UXBRIDGE STANDARDS. THIS ACCEPTANCE IS NOT TO BE CONSTRUED AS VERIFICATION OF ENGINEERING CONTENT.	APPROVED
AECOM CONSULTING	DEPARTMENT OF WORKS
DATE	REGIONAL OF DURHAM
	DATE

REVISIONS				
No.	DESCRIPTION	TOWN	DATE	INITIAL
2				
1	ISSUED FOR SPA	UXBRIDGE	01/08/21	K.L.

**THE TOWNSHIP OF UXBRIDGE**

**DETAIL PLAN**

HERREMA BOULEVARD & BROCK ROAD  
UXBRIDGE ONTARIO



7800 KENNEDY ROAD  
SUITE 201  
MARKHAM, ONTARIO  
L3R 9C7  
T: (905) 944-0162  
www.masong.ca

	SCALE	1:200	PROJECT No.	20-028
	DATE	JULY 2020	DRAWING No.	
	DESIGN	K.L.	<b>DET1</b>	
	CHECKED	A.L.		

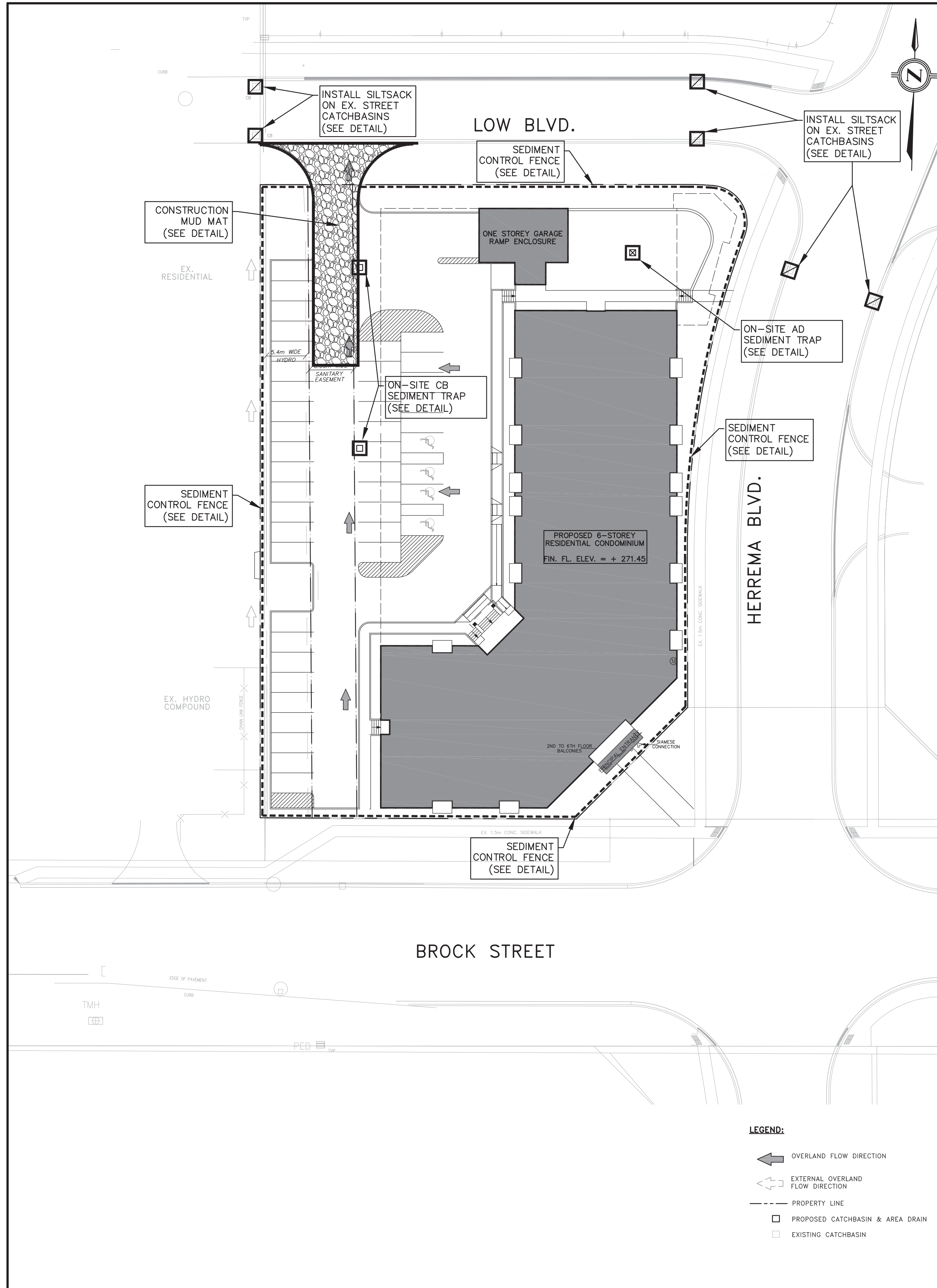

- EROSION AND SEDIMENT CONTROL NOTES:**
- ALL EROSION CONTROL MEASURES SUCH AS SEDIMENT CONTROL FENCE, TEMPORARY PONDS, CONSTRUCTION ACCESS MATS, SEDIMENT TRAPS, SWALES AND CHECK DAMS MUST BE INSTALLED PRIOR TO THE COMMENCEMENT OF SITE WORKS.
  - SEDIMENT CONTROLS SHOULD BE INSPECTED ON A REGULAR BASIS AND AFTER EVERY SIGNIFICANT RAINFALL EVENT. REPAIRS TO ESC MEASURES MUST BE COMPLETED IN A TIMELY MANNER TO PREVENT SEDIMENT INFILTRATION.
  - ADDITIONAL MATERIALS SUCH AS CLEAR STONE, FILTER FABRIC, PUMPS, HOSES AND SILTSACKS TO BE KEPT ON-SITE AT ALL TIMES FOR CONDUCTING REPAIRS TO SEDIMENT CONTROL MEASURES.
  - ALL DISTURBED AREAS LEFT INACTIVE FOR MORE THAN THIRTY DAYS ARE TO BE STABILIZED.
  - THE STABILIZATION SEED MIXTURE IS TO BE AS SPECIFIED ON THE EROSION AND SEDIMENT CONTROL PLAN.
  - THE STABILIZATION SEED MIXTURE IS TO BE APPLIED AT A MINIMUM RATE OF 25 kg/m<sup>2</sup>.
  - ENGINEERED CHANGES TO THE ESC MEASURES MAY BE REQUIRED AS SITE CONDITIONS CHANGE THROUGHOUT THE CONSTRUCTION PROCESS. THESE UPDATES MUST REFLECT BEST MANAGEMENT PRACTICES TO CONTROL SEDIMENT AND EROSION ON-SITE AND SHOULD BE COMPLETED BASED ON DIRECTION FROM THE SITE ENGINEER. ADDITIONAL MEASURES MAY BE REQUIRED AS DIRECTED BY AN ENGINEER THROUGHOUT THE CONSTRUCTION PROCESS.
  - THE CONSTRUCTION ENTRANCE MAT IS TO BE INSTALLED AS THE FIRST STEP IN THE SITE ALTERNATION PROCESS.
  - SEDIMENT CONTROL FENCE IS TO BE INSTALLED DOWNSTREAM OF ALL DISTURBED AREAS. A DOUBLE ROW OF SEDIMENT CONTROL FENCE IS TO BE INSTALLED SURROUNDING ALL NATURAL HERITAGE FEATURES AND AS DIRECTED BY THE SITE ENGINEER. SEDIMENT CONTROL FENCE IS TO BE AS PER LSRCA STANDARD ESC-4 OR ESC-5 AS A MINIMUM. LIGHT CUT SEDIMENT CONTROL FENCE IS NOT ACCEPTABLE.
  - CUT-OFF SWALES OR DITCHES ARE TO BE INSTALLED AS SHOWN ON THE ESC PLANS AND AS NECESSARY BASED ON CHANGING SITE CONDITIONS TO DIRECT OVERLAND FLOW TO THE APPROPRIATE SEDIMENT TRAP OR TEMPORARY SEDIMENT POND.
  - CHECK DAMS ARE TO BE INSTALLED IN ALL SWALES AND DITCHES IN ACCORDANCE WITH DRAWING LSRCA ESC-2, AS A MINIMUM.
  - TEMPORARY SEDIMENT TRAPS ARE TO BE CONSTRUCTED AT THE BEGINNING OF SITE GRADING AND IF THE SITE DRAINAGE CHANGES DURING CONSTRUCTION, IT MAY BE NECESSARY FOR TEMPORARY SWALES TO BE CONSTRUCTED TO DIRECT SITE FLOWS TO THE TEMPORARY SEDIMENT TRAPS DURING ROUGH GRADING AND AS CONSTRUCTION PROGRESSES.
  - TEMPORARY SEDIMENT PONDS ARE TO BE CONSTRUCTED AT THE BEGINNING OF SITE GRADING AND IF THE SITE DRAINAGE CHANGES DURING CONSTRUCTION, IT MAY BE NECESSARY FOR TEMPORARY SWALES TO BE CONSTRUCTED TO DIRECT SITE FLOWS TO THE TEMPORARY SEDIMENT PONDS DURING ROUGH GRADING AND AS CONSTRUCTION PROGRESSES.
  - IF STOCKPILES ARE USED ON-SITE FOR THE STORAGE OF EXCESS MATERIAL, THEY ARE TO BE IN ACCORDANCE WITH DETAIL DRAWING LSRCA ESC-6 OR BETTER.
  - ANY DEWATERING OCCURRING ON-SITE MUST BE IN ACCORDANCE WITH AN APPROVED DEWATERING PLAN. ADDITIONAL DEWATERING REQUIREMENTS MAY BE DEEMED NECESSARY AND SHALL BE IMPLEMENTED AS DIRECTED BY THE ENGINEER, CONTRACT ADMINISTRATOR OR LOCAL MUNICIPALITY.
  - EQUIPMENT AND HYDROCARBON STORAGE IS TO OCCUR ONLY WITHIN THE DESIGNATED AREA SHOWN ON THE PLANS.
  - REFUELLING IS TO TAKE PLACE ONLY WITHIN THE DESIGNATED AREA SHOWN ON THE PLANS AND SHALL BE A MINIMUM OF THIRTY METRES FROM ANY WATERCOURSE OR ENVIRONMENTALLY SENSITIVE AREA.
  - AN APPROVED SPILLS MANAGEMENT PLAN IS TO BE KEPT ON-SITE.
  - SPILL CLEANUP EQUIPMENT SUCH AS ADSORPTIVE MEDIA IS TO BE MAINTAINED ON-SITE FOR IMMEDIATE USE IN THE EVENT OF A SPILL.
  - SPILLS ARE TO BE REPORTED IMMEDIATELY TO THE MRC'S SPILLS ACTION CENTRE AT 1-800-268-6969.
  - THE CONTRACTOR WILL BE RESPONSIBLE FOR RESTORATION INCLUDING ALL COSTS DUE TO THE RELEASE OF SEDIMENT FROM THE SITE.
  - LOW IMPACT DEVELOPMENT (LID) MEASURES ARE NOT TO BE USED AS SEDIMENT CONTROL DEVICES.
  - ADDITIONAL SEDIMENT CONTROL DEVICES MAY BE DEEMED NECESSARY AND AS SITE CONDITIONS CHANGE AND SHALL BE INSTALLED AS DIRECTED BY THE SITE ENGINEER, CONTRACT ADMINISTRATOR OR LOCAL MUNICIPALITY.

1	SWM GUIDELINES UPDATE	06-2016	DATE: 06-2016
NO.	REVISION	DATE	SCALE: NTS

**EROSION AND SEDIMENT CONTROL PLAN NOTES**

LSRCA ESC-1

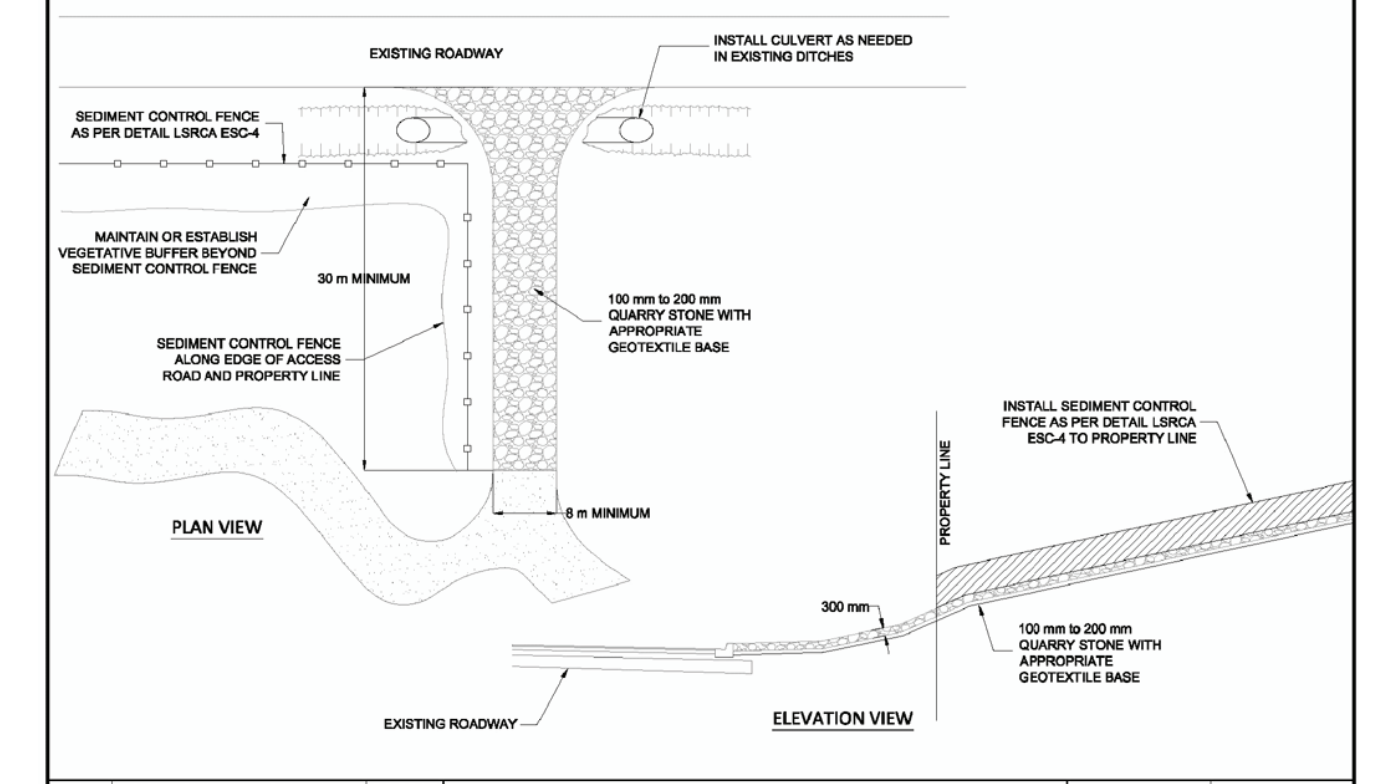

1	SWM GUIDELINES UPDATE	06-2016	DATE: 06-2016
NO.	REVISION	DATE	SCALE: NTS

**CONSTRUCTION ACCESS MAT**

LSRCA ESC-3

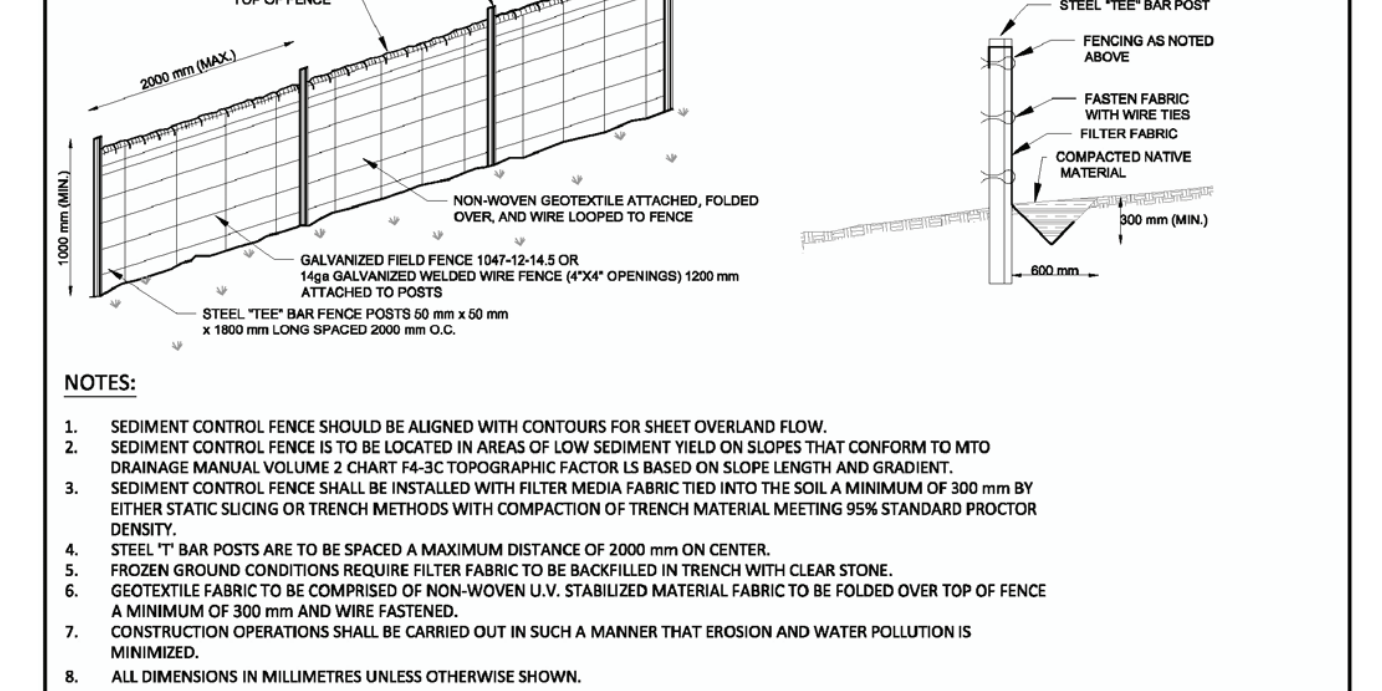

1	SWM GUIDELINES UPDATE	06-2016	DATE: 06-2016
NO.	REVISION	DATE	SCALE: NTS

**SEDIMENT CONTROL FENCE**

LSRCA ESC-4

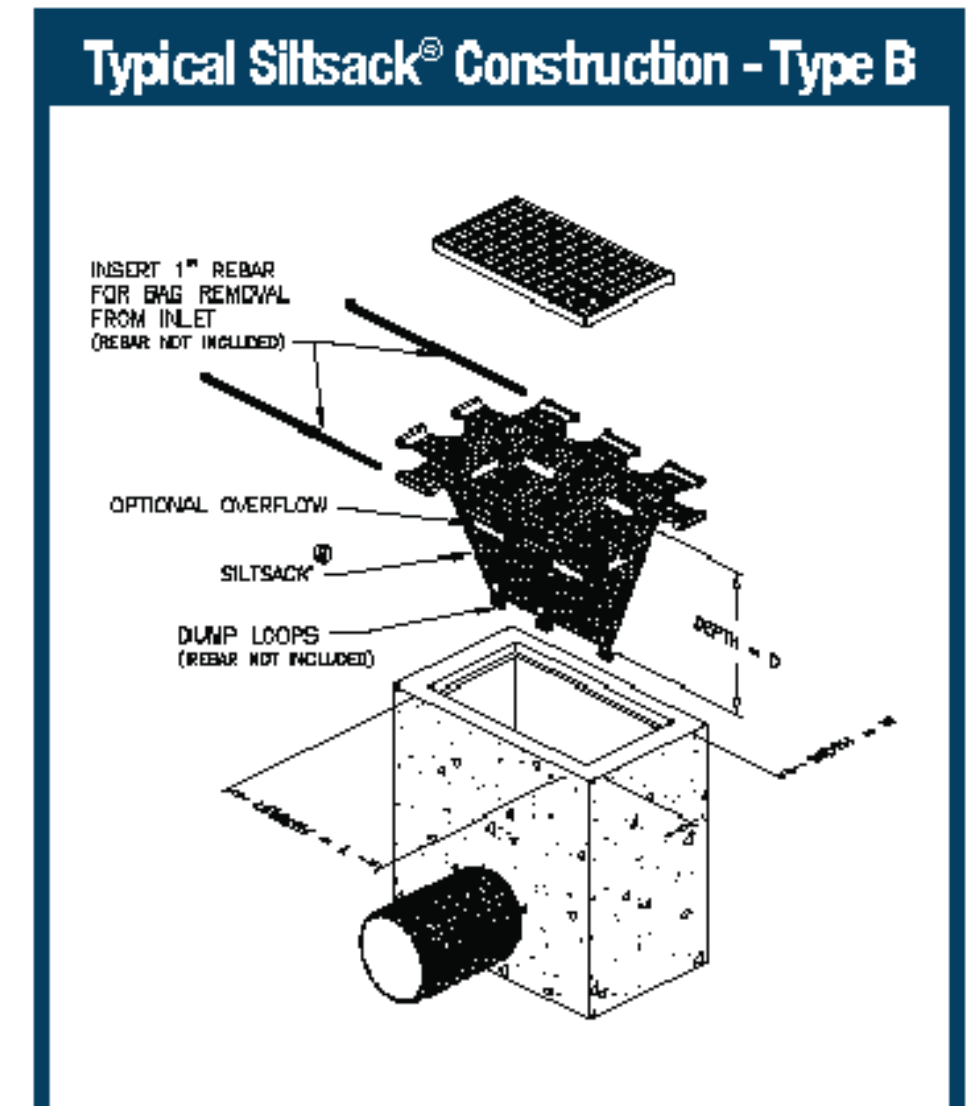
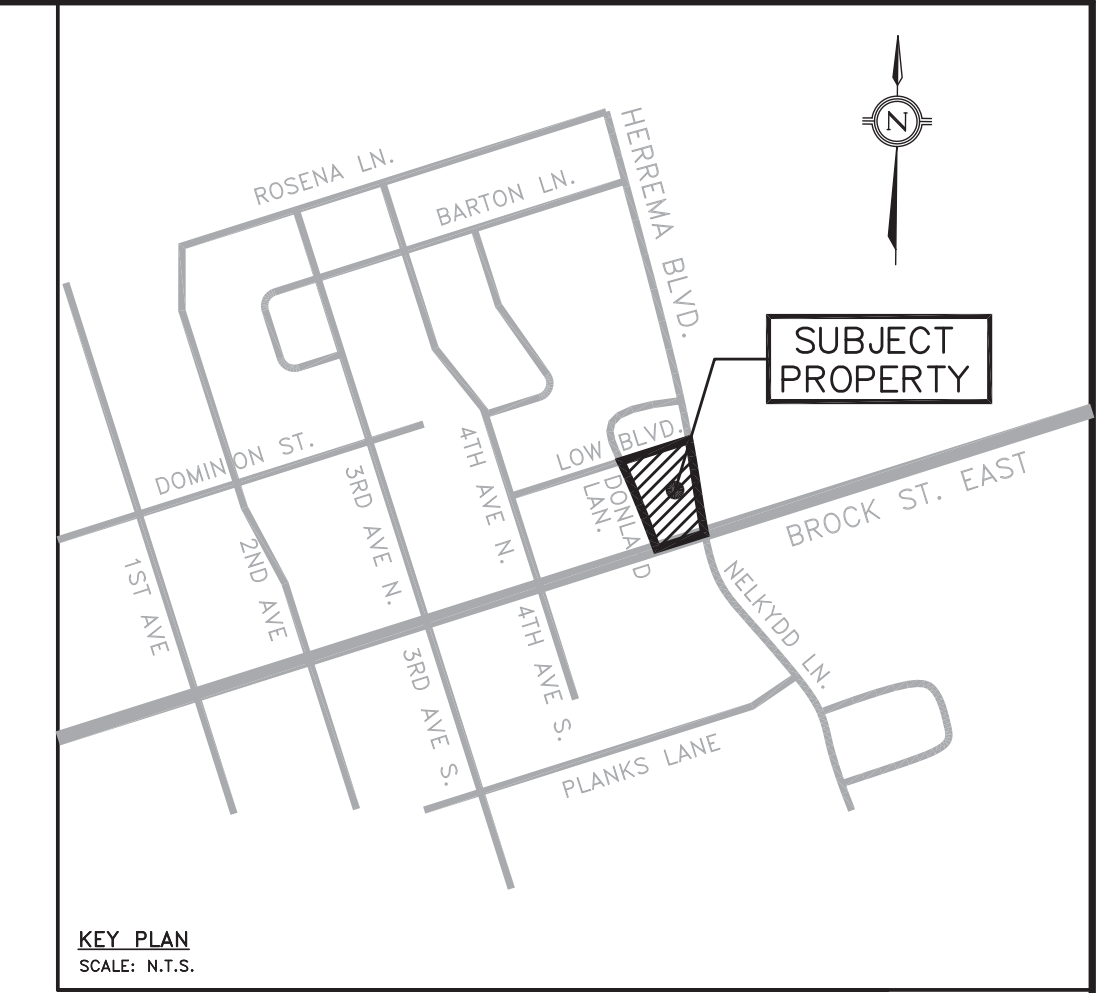
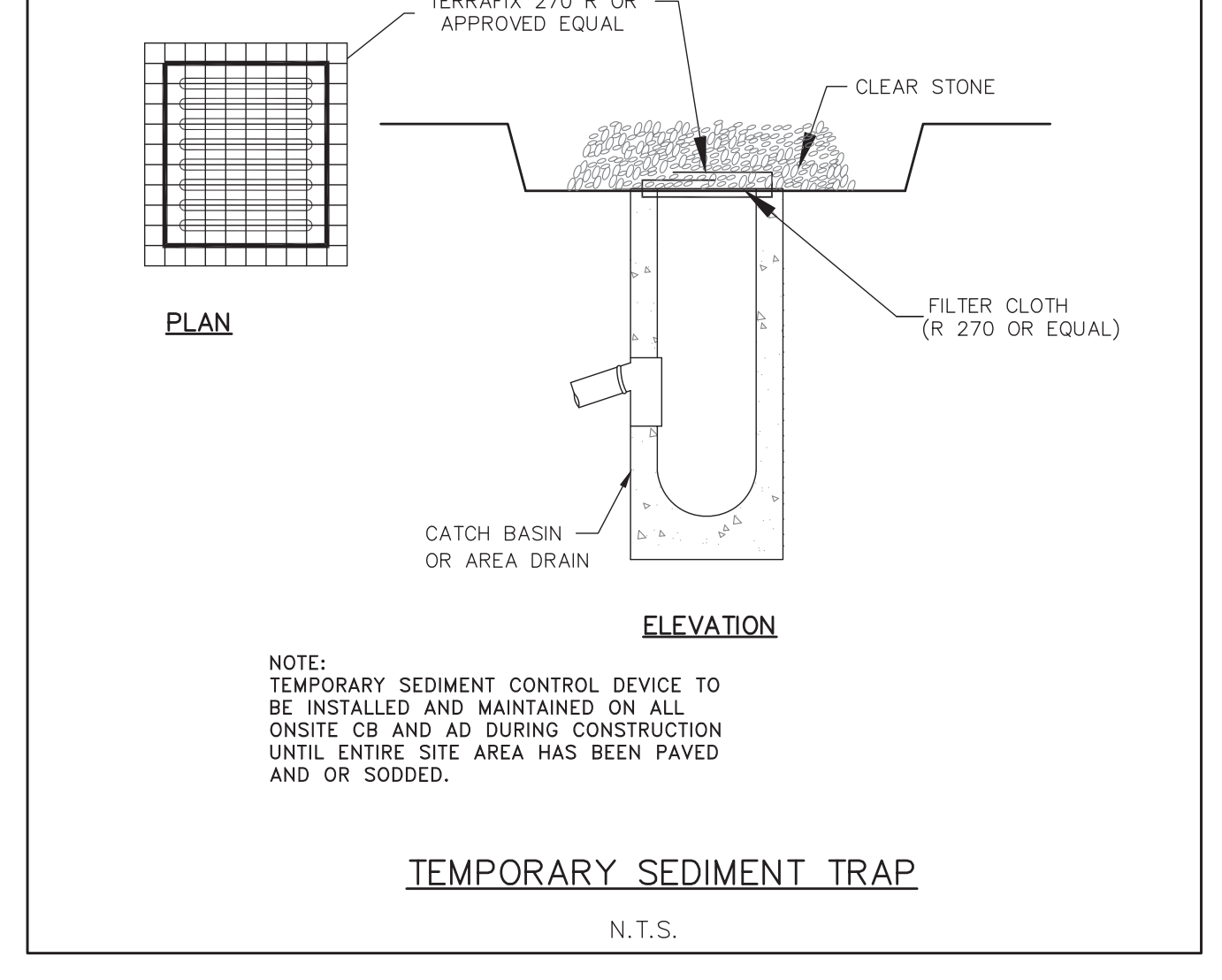

ACCEPTED TO BE IN ACCORDANCE WITH THE TOWNSHIP OF UXBRIDGE STANDARDS. THIS ACCEPTANCE IS NOT TO BE CONSTRUED AS VERIFICATION OF ENGINEERING CONTENT.	APPROVED
AECOM CONSULTING	DEPARTMENT OF WORKS
DATE	REGIONAL OF DURHAM
DATE	DATE

2	ISSUED FOR SPA	UXBRIDGE	01/08/21	K.L.
No.	DESCRIPTION	TOWN	DATE	INITIAL

REVISIONS

**THE TOWNSHIP OF UXBRIDGE**

**EROSION AND SEDIMENT CONTROL PLAN**

HERREMA BOULEVARD & BROCK ROAD  
UXBRIDGE ONTARIO

**MASONGSONG ASSOCIATES**

7800 KENNEDY ROAD  
SUITE 201  
MARKHAM, ONTARIO  
L3R 9C7  
T: (905) 944-1162  
www.masong.ca

PROJECT No. 20-028

DATE: JULY 2020

DESIGN: K.L.

DRAWN: K.L.

CHECKED: A.I.

DRAWING No. ESC1





**Municipal and Development  
Engineering**



**Water Resources Engineering**



**Planning**



**Project Management**

**MASONGSONG ASSOCIATES ENGINEERING LIMITED**

Consulting Engineers • Planners • Project Managers

Markham Head Office

7800 Kennedy Road, Suite 201  
Markham, Ontario  
L3R 2C7

T: (905) 944-0162  
F: (905) 944-0165

W: [www.maeng.ca](http://www.maeng.ca)

